

# MAX336/MAX337

# 16-Channel/Dual 8-Channel, Low-Leakage, CMOS Analog Multiplexers

## General Description

The MAX336/MAX337 are monolithic, CMOS analog multiplexers (muxes). The 16-channel MAX336 is designed to connect one of 16 inputs to a common output by control of a 4-bit binary address. The dual, 8-channel MAX337 is designed to connect one of eight inputs to a common output by control of a 3-bit binary address. Both devices can be used as either a mux or a demux. On-resistance is 400Ω (max), and the devices conduct current equally well in both directions.

These muxes feature extremely low off leakages (less than 20pA at +25°C) and on-channel leakages (less than 50pA at +25°C). The new design offers guaranteed low charge injection (3.5pC, typ) and electrostatic discharge (ESD) protection greater than 2000V, per method 3015.7. These improved muxes are pin-compatible upgrades for the industry-standard DG506 and DG507.

The MAX336/MAX337 operate from a single +4.5V to +30V supply or from dual ±4.5V to ±20V supplies. All control inputs (whether address or enable) are TTL compatible (0.8V to 2.4V) over the full specified temperature range and over the ±4.5V to ±18V supply range.

## Applications

- Precision Data Acquisition
- Precision Signal Routing
- Test Equipment

## Benefits and Features

- < 400Ω (max) On-Resistance
- < 500ns Transition Time
- < 10Ω On-Resistance Match
- < 20pA NO-Off Leakage Current at +25°C
- 3.5pC Charge Injection
- +4.5V to +30V Single Supply  
±4.5V to ±20V Dual Supplies
- Plug-In Upgrade for Industry-Standard DG506/DG507
- Bidirectional Rail-to-Rail® Signal Handling
- TTL/CMOS-Logic Compatible
- > 2000V ESD Protection, per Method 3015.7

## Ordering Information

PART	TEMP-RANGE	PIN-PACKAGE
MAX336CPI+	0°C to +70°C	28 Plastic DIP
MAX336CWI+	0°C to +70°C	28 Wide SO
MAX336CAI+	0°C to +70°C	28 SSOP
MAX336C/D	0°C to +70°C	Dice*

*Ordering Information appears at end of data sheet.*

*\* Contact factory for dice specifications.*

*+Denotes lead(Pb)-free/RoHS-compliant package.*

## Pin Configurations/Functional Diagrams/Truth Tables

TOP VIEW

MAX336

DIP/SO/SSOP/TSSOP  
N.C. = NO INTERNAL CONNECTION

MAX336 16-CHANNEL SINGLE-ENDED MULTIPLEXER

MAX336					
A3	A2	A1	A0	EN	ON SWITCH
X	X	X	X	0	NONE
0	0	0	0	1	1
0	0	0	1	1	2
0	0	1	0	1	3
0	0	1	1	1	4
0	1	0	0	1	5
0	1	0	1	1	6
0	1	1	0	1	7
0	1	1	1	1	8
1	0	0	0	1	9
1	0	0	1	1	10
1	0	1	0	1	11
1	0	1	1	1	12
1	1	0	0	1	13
1	1	0	1	1	14
1	1	1	0	1	15
1	1	1	1	1	16

LOGIC "0" = V<sub>AL</sub> ≤ 0.8V, LOGIC "1" = V<sub>AH</sub> ≥ 2.4V

Continued at end of data sheet.

Rail-to-Rail is a registered trademark of Nippon Motorola Ltd.



**Absolute Maximum Ratings**

Voltage Referenced to V-		TSSOP (derate 12.80mW/°C above +70°C).....1025.60mW
V+.....	-0.3V, 44V	Wide SO (derate 12.50mW/°C above +70°C).....1.00W
GND.....	-0.3V, 25V	SSOP (derate 9.10mW/°C above +70°C).....727.3mW
Digital Inputs, A_, EN_, NO, COM		CERDIP (derate 16.67mW/°C above +70°C).....1.33W
(Note 1).....	(V- - 0.3V) to (V+ + 0.3V)	Operating Temperature Ranges
or 30mA (whichever occurs first)		MAX336C_I/MAX337C_I.....0°C to +70°C
Continuous Current (any terminal).....	30mA	MAX336E_I/MAX337E_I.....-40°C to +85°C
Peak Current, NO or COM		MAX336MJI/MAX337MJI.....-55°C to +125°C
(pulsed at 1ms, 10% duty cycle max).....	100mA	Storage Temperature Range .....-65°C to +150°C
Continuous Power Dissipation (T <sub>A</sub> = +70 °C)		Lead Temperature (soldering, 10sec) .....+300°C
Plastic DIP (derate 14.29mW/°C above +70°C).....	1.14W	Soldering Temperature (reflow)..... +260°C
Plastic DIP (derate 14.30,W/°C above +70°C).....	1142.90mW	

**Note 1:** Signals on any terminal exceeding V+ or V- are clamped by internal diodes. Limit forward current to maximum current rating.

Stresses beyond those listed under "Absolute Maximum Ratings" may cause permanent damage to the device. These are stress ratings only, and functional operation of the device at these or any other conditions beyond those indicated in the operational sections of the specifications is not implied. Exposure to absolute maximum rating conditions for extended periods may affect device reliability.

**Electrical Characteristics—Dual Supplies**

(V+ = +15V, V- = -15V, GND = 0V, V<sub>AH</sub> = +2.4V, V<sub>AL</sub> = +0.8V, T<sub>A</sub> = T<sub>MIN</sub> to T<sub>MAX</sub>, unless otherwise noted.)

PARAMETER	SYMBOL	CONDITIONS		MIN	TYP (Note 2)	MAX	UNITS		
<b>SWITCH</b>									
Analog Signal Range	V <sub>NO</sub> , V <sub>COM</sub>	(Note 3)		-15		15	V		
On-Resistance	R <sub>ON</sub>	I <sub>NO</sub> = 0.2mA, V <sub>COM</sub> = ±10V	T <sub>A</sub> = +25 °C		220	400	Ω		
			T <sub>A</sub> = T <sub>MIN</sub> to T <sub>MAX</sub>			500			
On-Resistance Matching Between Channels	ΔR <sub>ON</sub>	I <sub>NO</sub> = 0.2mA, V <sub>COM</sub> = ±10V (Note 4)	T <sub>A</sub> = +25 °C		5	10	Ω		
			T <sub>A</sub> = T <sub>MIN</sub> to T <sub>MAX</sub>			15			
NO-Off Leakage Current (Note 5)	I <sub>NO(OFF)</sub>	V <sub>COM</sub> = ±10V, V <sub>NO</sub> = ±10V, V <sub>EN</sub> = 0V	T <sub>A</sub> = +25 °C		-0.02	0.001	nA		
			T <sub>A</sub> = T <sub>MIN</sub> to T <sub>MAX</sub>	C, E		-1.25		1.25	
				M		-20		20	
COM-Off Leakage Current (Note 5)	I <sub>COM(OFF)</sub>	V <sub>NO</sub> = ±10V, V <sub>COM</sub> = ±10V, V <sub>EN</sub> = 0V	MAX336	T <sub>A</sub> = +25 °C		-0.05	0.05	nA	
				T <sub>A</sub> = T <sub>MIN</sub> to T <sub>MAX</sub>	C, E		-6.5		6.5
					M		-80		80
		V <sub>NO</sub> = ±10V, V <sub>COM</sub> = ±10V, V <sub>EN</sub> = 0V	MAX337	T <sub>A</sub> = +25 °C		-0.05	0.05		
				T <sub>A</sub> = T <sub>MIN</sub> to T <sub>MAX</sub>	C, E		-3.25		3.25
					M		-40		40
COM-On Leakage Current (Note 5)	I <sub>COM(ON)</sub>	V <sub>COM</sub> = ±10V, V <sub>NO</sub> = ±10V, sequence each switch on	MAX336	T <sub>A</sub> = +25 °C		-0.05	0.05	nA	
				T <sub>A</sub> = T <sub>MIN</sub> to T <sub>MAX</sub>	C, E		-6.5		6.5
					M		-80		80
		MAX337	T <sub>A</sub> = +25 °C		-0.05	0.05			
			T <sub>A</sub> = T <sub>MIN</sub> to T <sub>MAX</sub>	C, E		-3.25	3.25		
				M		-40	40		

**Electrical Characteristics—Dual Supplies (continued)**(V+ = +15V, V- = -15V, GND = 0V, V<sub>AH</sub> = +2.4V, V<sub>AL</sub> = +0.8V, T<sub>A</sub> = T<sub>MIN</sub> to T<sub>MAX</sub>, unless otherwise noted.)

PARAMETER	SYMBOL	CONDITIONS	MIN	TYP (Note 2)	MAX	UNITS	
<b>INPUT</b>							
Input Current with Input Voltage High	I <sub>AH</sub>	V <sub>A</sub> = 2.4V or 15V	-1.0	0.001	1.0	μA	
Input Current with Input Voltage Low	I <sub>AL</sub>	V <sub>EN</sub> = 0V or 2.4V, V <sub>A</sub> = 0V	-1.0		1.0	μA	
<b>SUPPLY</b>							
Power-Supply Range			±4.5		±20	V	
Positive Supply Current	I+	V <sub>EN</sub> = V <sub>A</sub> = 0V	T <sub>A</sub> = +25°C	-1	0.01	1	μA
			T <sub>A</sub> = T <sub>MIN</sub> to T <sub>MAX</sub>	-10		10	
		V <sub>EN</sub> = 2.4V, V <sub>A(ALL)</sub> = 2.4V	T <sub>A</sub> = +25°C		400	700	
			T <sub>A</sub> = T <sub>MIN</sub> to T <sub>MAX</sub>			1100	
Negative Supply Current	I-	V <sub>EN</sub> = 0V or 2.4V; V <sub>A(ALL)</sub> = 0V, 2.4V, or 5V	T <sub>A</sub> = +25°C	-1		1	μA
			T <sub>A</sub> = T <sub>MIN</sub> to T <sub>MAX</sub>	-10		10	
<b>DYNAMIC</b>							
Transition Time	t <sub>TRANS</sub>	Figure 2, T <sub>A</sub> = +25°C		200	500	ns	
Break-Before-Make Interval	t <sub>OPEN</sub>	Figure 4, T <sub>A</sub> = +25°C	10	50		ns	
Enable Turn-On Time	t <sub>ON(EN)</sub>	Figure 3	T <sub>A</sub> = +25°C		250	500	ns
			T <sub>A</sub> = T <sub>MIN</sub> to T <sub>MAX</sub>			750	
Enable Turn-Off Time	t <sub>OFF(EN)</sub>	Figure 3	T <sub>A</sub> = +25°C		100	500	ns
			T <sub>A</sub> = T <sub>MIN</sub> to T <sub>MAX</sub>			750	
Charge Injection (Note 3)	Q	C <sub>L</sub> = 100pF, V <sub>NO</sub> = 0V, R <sub>S</sub> = 0Ω, Figure 6, T <sub>A</sub> = +25°C		3.5	10	pC	
Off Isolation (Note 6)	V <sub>ISO</sub>	V <sub>EN</sub> = 0V, R <sub>L</sub> = 1kΩ, f = 100kHz, T <sub>A</sub> = +25°C		-82		dB	
Crosstalk Between Channels	V <sub>CT</sub>	V <sub>EN</sub> = 2.4V, f = 100kHz, V <sub>GEN</sub> = 1Vp-p, R <sub>L</sub> = 1kΩ, Figure 7, T <sub>A</sub> = +25°C		-86		dB	
Logic Input Capacitance	C <sub>IN</sub>	f = 1MHz, T <sub>A</sub> = +25°C		2		pF	
NO-Off Capacitance	C <sub>NO(OFF)</sub>	f = 1MHz, V <sub>EN</sub> = V <sub>NO</sub> = 0V, Figure 8, T <sub>A</sub> = +25°C		2		pF	
COM-Off Capacitance	C <sub>COM(OFF)</sub>	f = 1MHz, V <sub>EN</sub> = 0.8V, V <sub>COM</sub> = 0V, Figure 8, T <sub>A</sub> = +25°C	MAX336		20	pF	
			MAX337		10		
COM-On Capacitance	C <sub>COM(ON)</sub>	f = 1MHz, V <sub>EN</sub> = 2.4V, V <sub>COM</sub> = 0V, Figure 8, T <sub>A</sub> = +25°C	MAX336		22	pF	
			MAX337		12		

**Electrical Characteristics—Single Supply**

(V+ = +12V, V- = 0V, GND = 0V, V<sub>AH</sub> = +2.4V, V<sub>AL</sub> = +0.8V, T<sub>A</sub> = T<sub>MIN</sub> to T<sub>MAX</sub>, unless otherwise noted.)

PARAMETER	SYMBOL	CONDITIONS	MIN	TYP (Note 2)	MAX	UNITS
<b>SWITCH</b>						
Analog Signal Range	V <sub>NO</sub> , V <sub>COM</sub>	(Note 3)	0		12	V
On-Resistance	R <sub>ON</sub>	I <sub>NO</sub> = 0.2mA, V <sub>COM</sub> = 3V or 10V, T <sub>A</sub> = +25°C		460	700	Ω
<b>DYNAMIC</b>						
Transition Time (Note 3)	t <sub>TRANS</sub>	V <sub>NO-</sub> = ±5V, V <sub>IN</sub> = 2.4V, Figure 1, T <sub>A</sub> = +25°C		350	600	ns
Enable Turn-On Time (Note 3)	t <sub>ON(EN)</sub>	V <sub>INH</sub> = 2.4V, V <sub>INL</sub> = 0V, V <sub>NO1</sub> = 5V, Figure 3, T <sub>A</sub> = +25°C		350	600	ns
Enable Turn-Off Time (Note 3)	t <sub>OFF(EN)</sub>	V <sub>INH</sub> = 2.4V, V <sub>INL</sub> = 0V, V <sub>NO1</sub> = 5V, Figure 3, T <sub>A</sub> = +25°C		110	500	ns
Charge Injection (Note 3)	Q	C <sub>L</sub> = 100pF, V <sub>NO</sub> = 0V, R <sub>S</sub> = 0Ω, T <sub>A</sub> = +25°C		5.0	10	pC

**Note 2:** The algebraic convention where the most negative value is a minimum and the most positive value a maximum is used in this data sheet.

**Note 3:** Guaranteed by design.

**Note 4:** ΔR<sub>ON</sub> = R<sub>ON</sub>(MAX) - R<sub>ON</sub>(MIN).

**Note 5:** Leakage parameters are 100% tested at the maximum rated hot temperature and guaranteed by correlation at T<sub>A</sub> = +25°C.

**Note 6:** Worst-case isolation is on channel 4 because of its proximity to the drain pin. Off isolation = 20log V<sub>COM</sub>/V<sub>NO</sub>, where V<sub>COM</sub> = output and V<sub>NO</sub> = input to off switch.

**Typical Operating Characteristics**

(T<sub>A</sub> = +25°C, unless otherwise noted.)

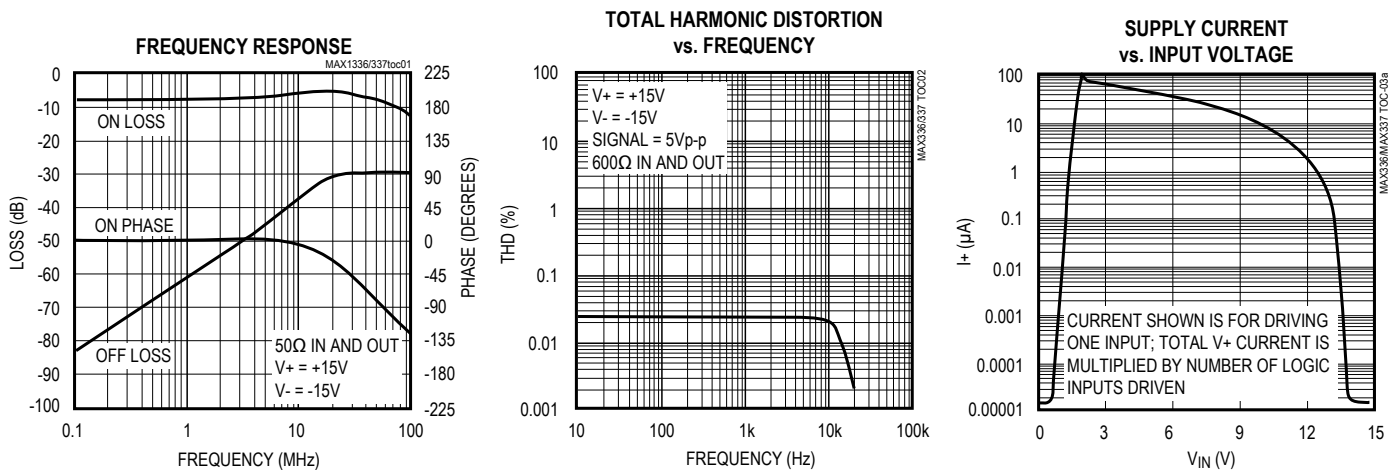

Typical Operating Characteristics (continued)

( $T_A = +25^\circ\text{C}$ , unless otherwise noted.)

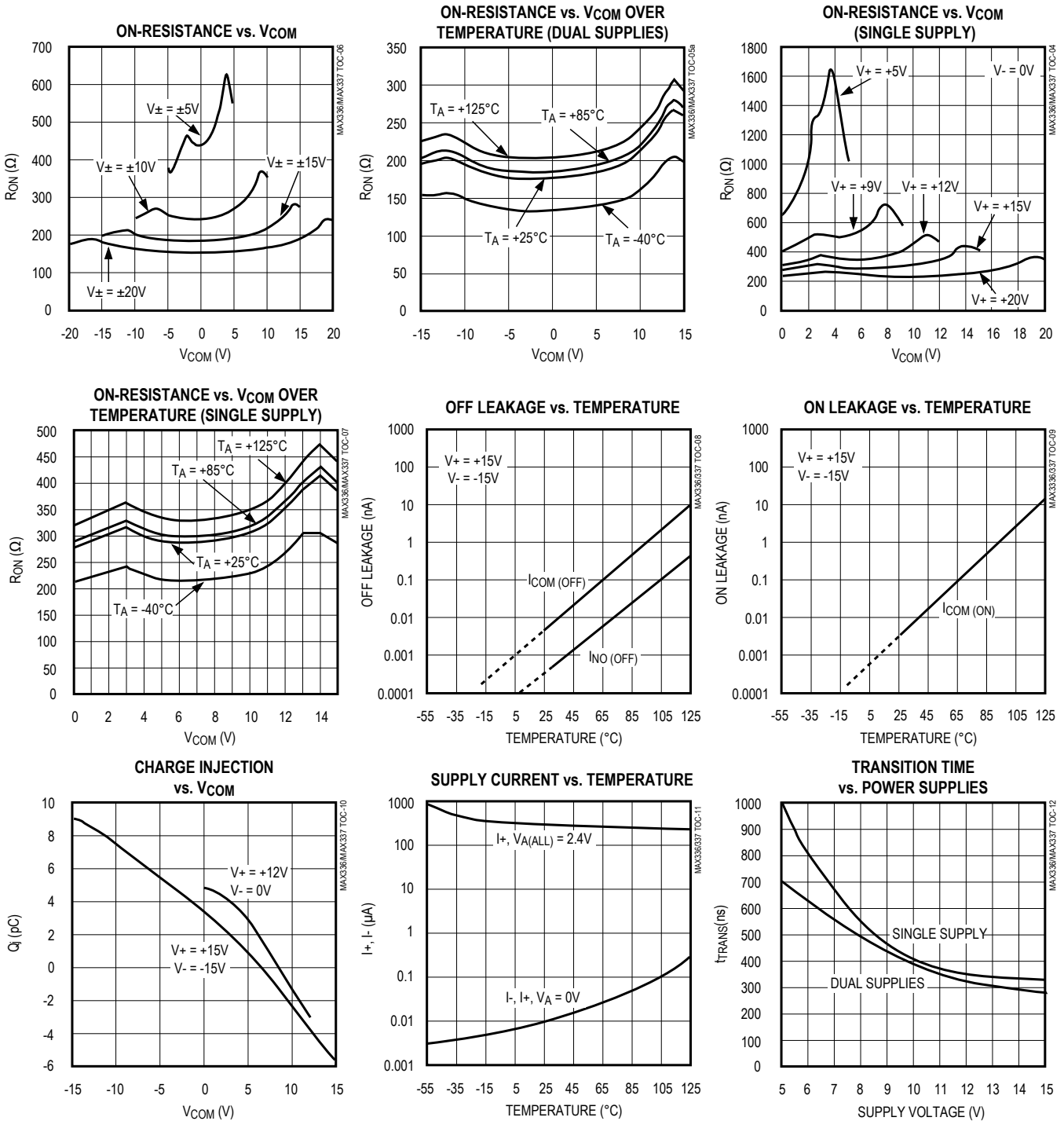

Pin Description

PIN		NAME	FUNCTION
MAX336	MAX337		
1	1	V+	Positive Supply-Voltage Input
2, 3, 13	3, 13, 14	N.C.	No Internal Connection
—	2	COMB	Analog Signal B Output* (bidirectional)
4–11	—	NO16–NO9	Analog Signal Inputs* (bidirectional)
—	4–11	NO8B–NO1B	Analog Signal B Inputs* (bidirectional)
12	12	GND	Logic Ground
14–17	—	A3–A0	Logic Address Inputs
—	15, 16, 17	A2, A1, A0	Logic Address Inputs
18	18	EN	Logic Enable Input
19–26	—	NO1–NO8	Analog Signal Inputs* (bidirectional)
—	19–26	NO1A–NO8A	Analog Signal A Inputs* (bidirectional)
27	27	V-	Negative Supply-Voltage Input. Connect to GND for single-supply operation.
28	—	COM	Analog Signal Output* (bidirectional)
—	28	COMA	Analog Signal A Output* (bidirectional)

\* Analog signal inputs and outputs are names of convenience only; they are identical and interchangeable.

Applications Information

Operation with Supply Voltages Other than 15V

Using supply voltages less than ±15V will reduce the analog signal range. The MAX336/MAX337 switches operate with ±4.5V to ±20V bipolar supplies or with a +4.5V to +30V single supply. Connect V- to GND when operating with a single supply. Both device types can also operate with unbalanced supplies such as +24V and -5V. The [Typical Operating Characteristics](#) graphs show typical on-resistance with 20V, 15V, 10V, and 5V supplies. (Switching times increase by a factor of two or more for operation at 5V.)

Overvoltage Protection

Proper power-supply sequencing is recommended for all CMOS devices. Do not exceed the absolute maximum ratings, because stresses beyond the listed ratings may cause permanent damage to the devices. Always sequence V+ on first, then V-, followed by the logic inputs NO and COM. If power-supply sequencing is not possible, add two small signal diodes in series with supply pins for overvoltage protection ([Figure 1](#)). Adding diodes reduces the analog signal range to 1V below V+

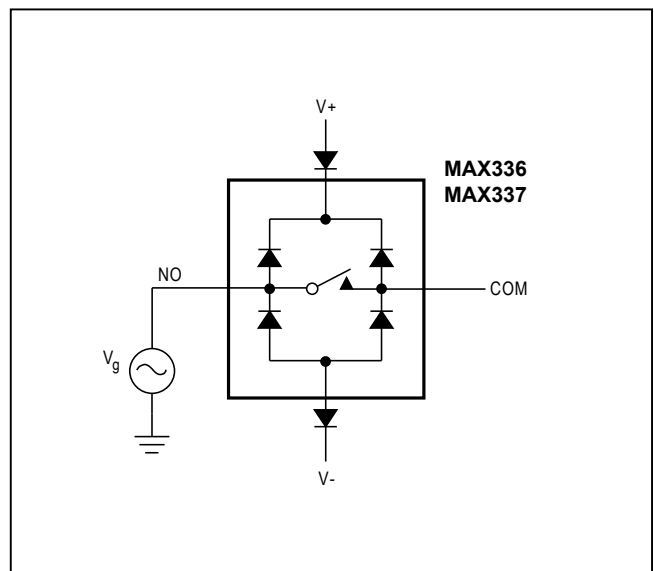

Figure 1. Overvoltage Protection Using External Blocking Diodes

and 1V above V-, but does not significantly affect the devices' low switch resistance and low leakage characteristics. Device operation is unchanged, and the difference between V+ and V- should not exceed 44V.

Test Circuits/Timing Diagrams

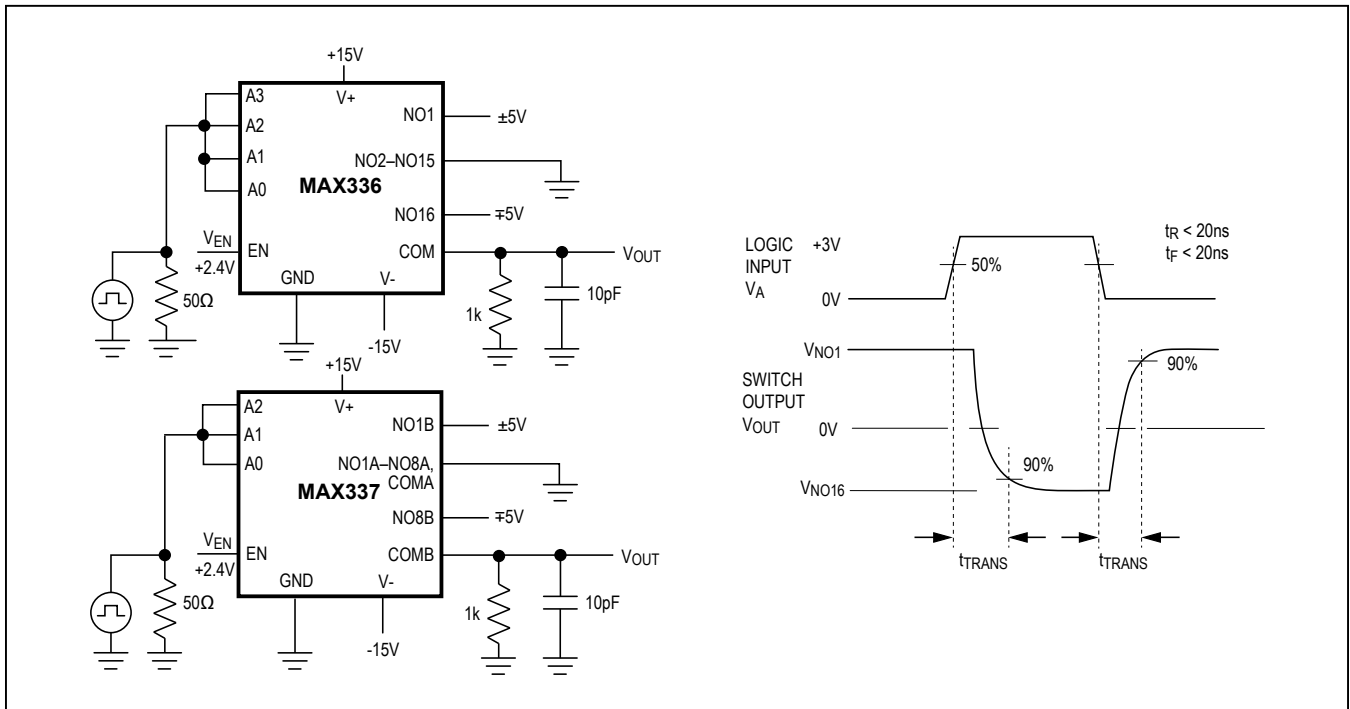

Figure 2. Transition Time

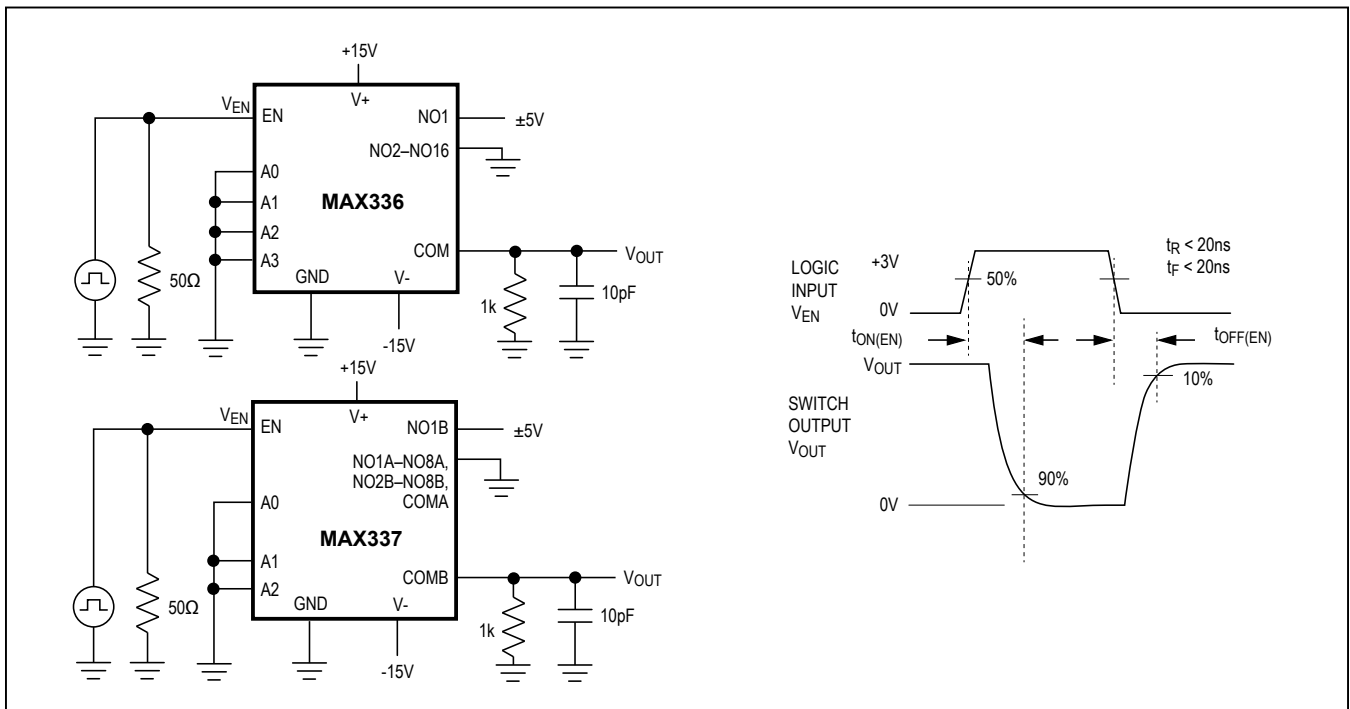

Figure 3. Enable Switching Time

Test Circuits/Timing Diagrams (continued)

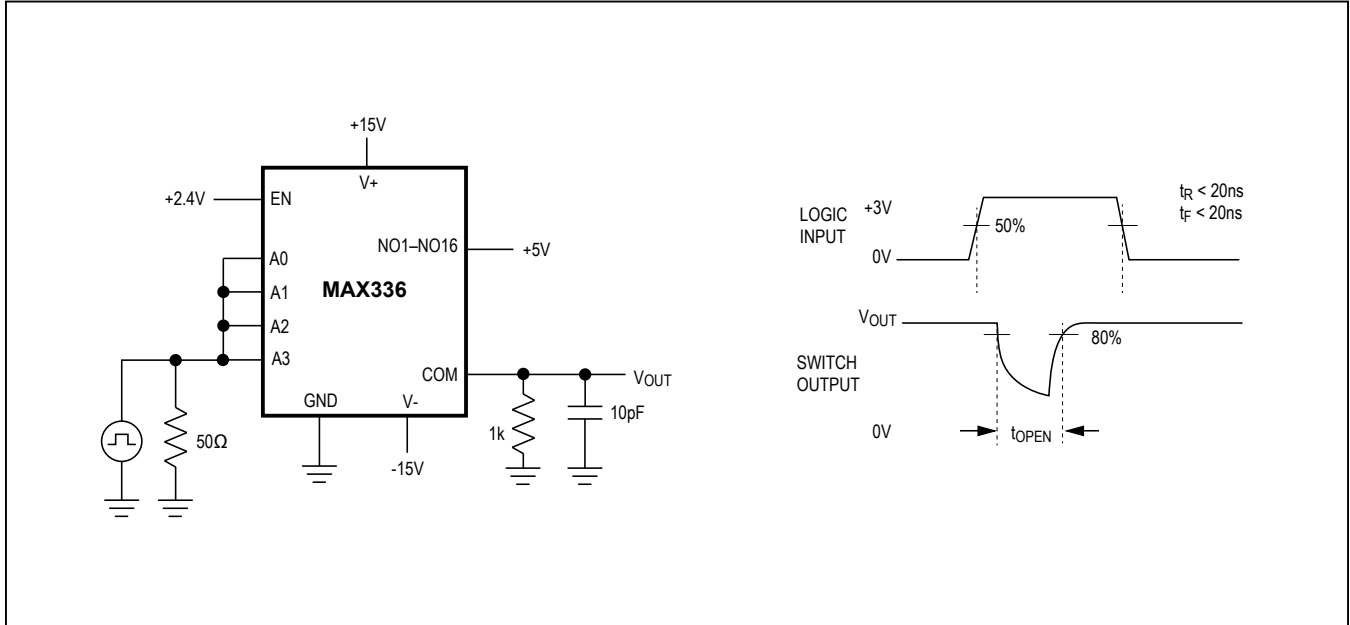

Figure 4. Break-Before-Make Interval

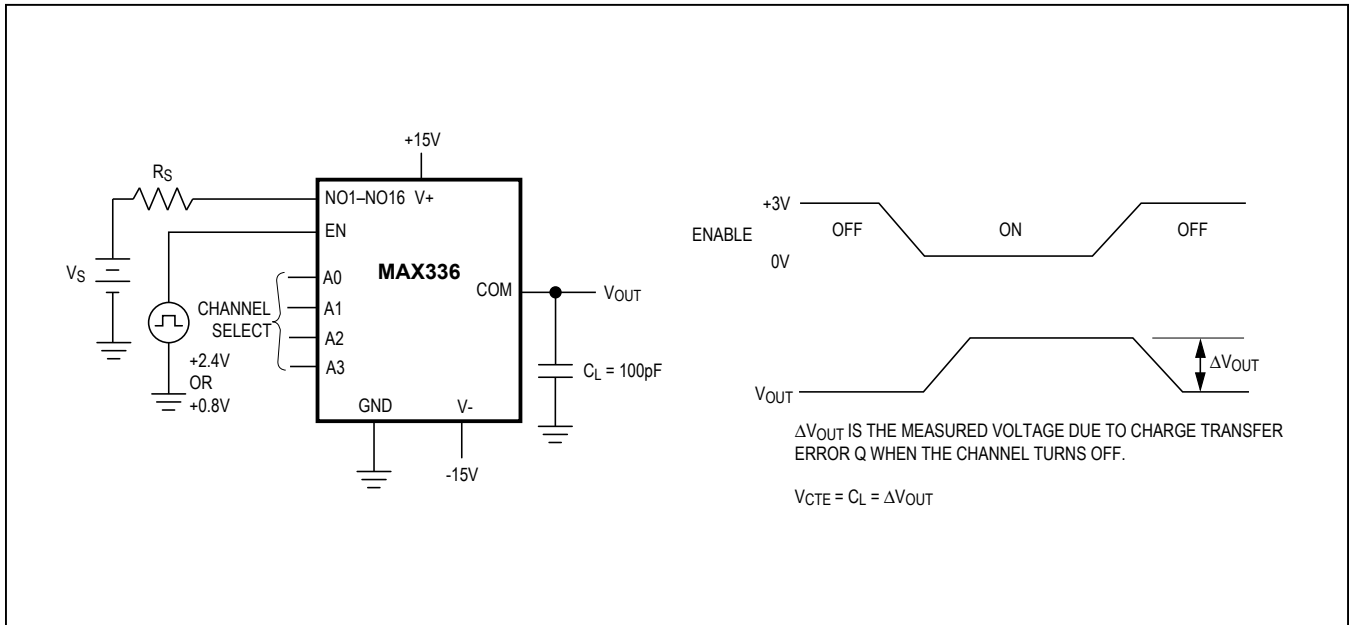

Figure 5. Charge Injection (VCTE)

Test Circuits/Timing Diagrams (continued)

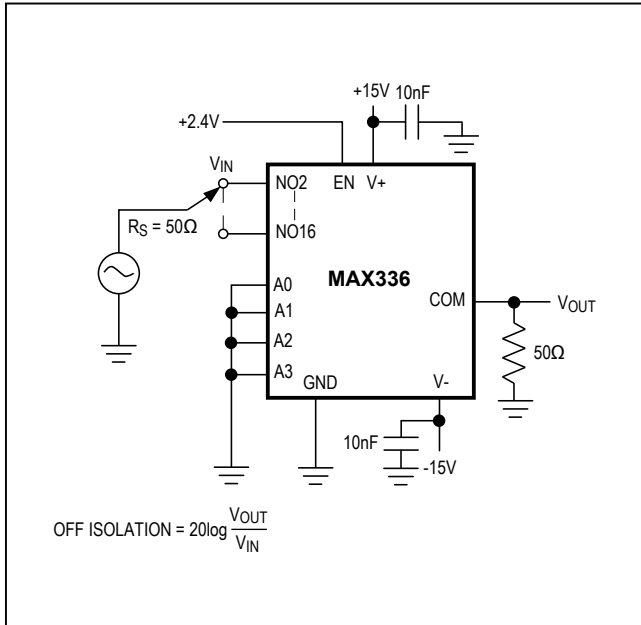

Figure 6. Off Isolation

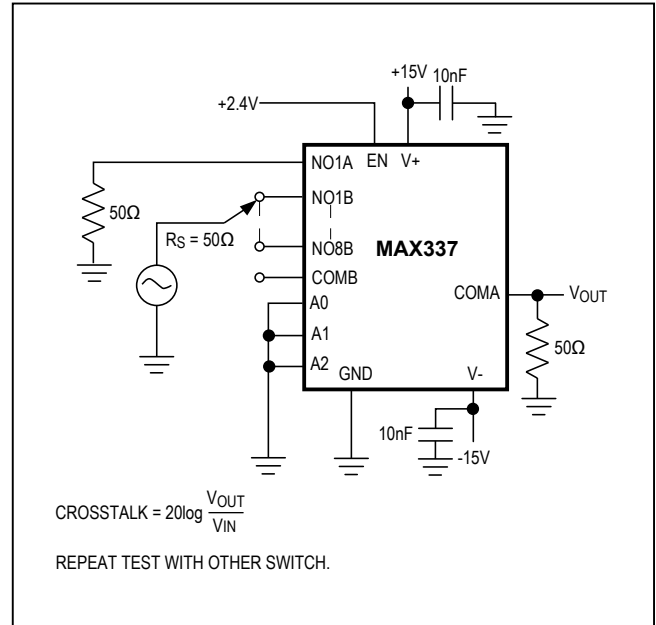

Figure 7. Crosstalk

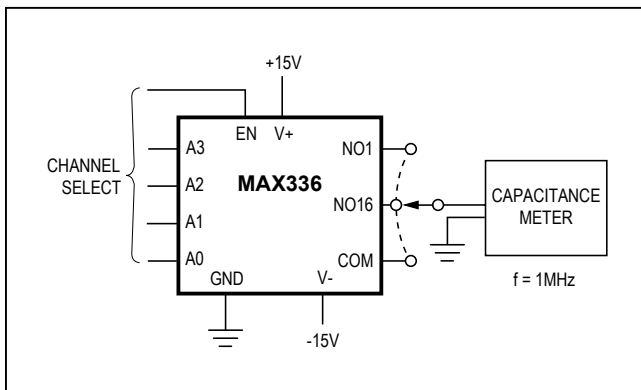
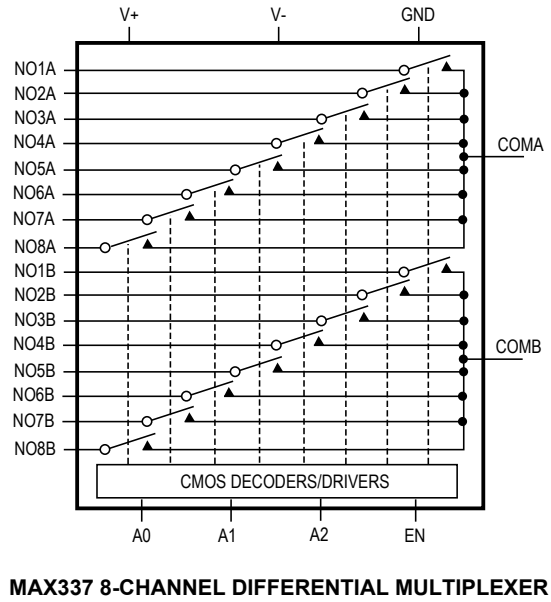
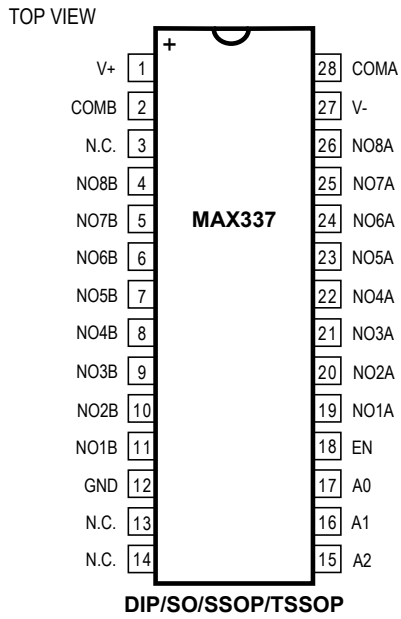

Figure 8. NO/COM Capacitance

Pin Configurations/Functional Diagrams/Truth Tables (continued)



MAX337				
A2	A1	A0	EN	ON SWITCH
X	X	X	0	NONE
0	0	0	1	1
0	0	1	1	2
0	1	0	1	3
0	1	1	1	4
1	0	0	1	5
1	0	1	1	6
1	1	0	1	7
1	1	1	1	8

LOGIC "0" =  $V_{AL} \leq 0.8V$ , LOGIC "1" =  $V_{AH} \geq 2.4V$

**Ordering Information (continued)**

PART	TEMP- RANGE	PIN-PACKAGE
<b>MAX336</b> EPI+	-40° C to +85° C	28 Plastic DIP
MAX336EWI+	-40° C to +85° C	28 Wide SO
MAX336EAI+	-40° C to +85° C	28 SSOP
MAX336EJI	-40° C to +85° C	28 CERDIP**
MAX336MJI	-55° C to +125° C	28 CERDIP**
<b>MAX337</b> CPI+	0° C to +70° C	28 Plastic DIP
MAX337CWI+	0° C to +70° C	28 Wide SO
MAX337CAI+	0° C to +70° C	28 SSOP
MAX337C/D	0° C to +70° C	Dice*
MAX337EPI+	-40° C to +85° C	28 Plastic DIP
MAX337EWI+	-40° C to +85° C	28 Wide SO
MAX337EAI+	-40° C to +85° C	28 SSOP
MAX337EJI	-40° C to +85° C	28 CERDIP**
MAX337MJI	-55° C to +125° C	28 CERDIP**

\* Contact factory for dice specifications.

\*\* Contact factory for availability.

+ Denotes lead(Pb)-free/RoHS compliant package.

**Chip Information**

PROCESS: BiCMOS

**Package Information**

For the latest package outline information and land patterns (footprints), go to [www.maximintegrated.com/packages](http://www.maximintegrated.com/packages). Note that a "+", "#", or "-" in the package code indicates RoHS status only. Package drawings may show a different suffix character, but the drawing pertains to the package regardless of RoHS status.

PACKAGE TYPE	PACKAGE CODE	OUTLINE NO.	LAND PATTERN NO.
28 Plastic DIP	P28+2	<a href="#">21-0044</a>	—
28 SSOP	A28+1	<a href="#">21-0056</a>	<a href="#">90-0095</a>
28 TSSOP	U28+2	<a href="#">21-0066</a>	<a href="#">90-0171</a>
28 WIDE SO	W28+6	<a href="#">21-0042</a>	<a href="#">90-0109</a>

## Revision History

REVISION NUMBER	REVISION DATE	DESCRIPTION	PAGES CHANGED
0	4/97	Initial release	—
1	10/14	Adding MAX336CUI/EUI to Ordering Information and adding TSSOP package	1, 2, 11, 12

For pricing, delivery, and ordering information, please contact Maxim Direct at 1-888-629-4642, or visit Maxim Integrated's website at [www.maximintegrated.com](http://www.maximintegrated.com).

*Maxim Integrated cannot assume responsibility for use of any circuitry other than circuitry entirely embodied in a Maxim Integrated product. No circuit patent licenses are implied. Maxim Integrated reserves the right to change the circuitry and specifications without notice at any time. The parametric values (min and max limits) shown in the Electrical Characteristics table are guaranteed. Other parametric values quoted in this data sheet are provided for guidance.*