

Types KCGG 122, 142 and KCEG 112, 142, 152, 242 Overcurrent Protection

Features

- Compact multi-function numerical relay
- Versions with integral directionality (KCEG)
- Serial communications
- Comprehensive protection functions including:
 - 3 stage overcurrent
 - 4 stage earth fault
 - restricted earth fault
 - 9 IDMT curves including IEC, ANSI/IEEE
 - thermal overload alarm and trip
 - underfrequency
 - undercurrent
 - breaker failure
 - undervoltage
 - rectifier protection
 - broken conductor detection
- Two setting groups
- Extensive measurement facilities
- Fault records for the last five faults
- Integral disturbance recorder accessible from a remote PC
- Integral event recorder accessible from a remote PC
- Circuit breaker maintenance alarm
- Phase segregated outputs



Figure 1: Relay type KCEG 142

Introduction

The range of overcurrent relays provides comprehensive protection for phase and earth faults, together with measurements, communications, control and recording facilities.

Within the range, the KCGG relays provide non-directional overcurrent and earth fault protection, while the KCEG relays allow each stage of protection to be selectively directionalised.

The relays in the range are designed to operate with a wide range of ac or dc auxiliary power supplies. If a secure supply is not available, the KCEG242 model can be powered from either an auxiliary supply (ac or dc) or from the CT circuit. Thus in the event of auxiliary supply failure, tripping functions will remain operational.

Models Available

KCGG 122

Single phase overcurrent and/or earth fault relay

KCGG 142

Three phase overcurrent and earth fault relay

KCEG 112

Directional earth fault relay

KCEG 142

Three phase directional overcurrent and directional earth fault relay

KCEG 152

Three phase overcurrent and directional earth fault relay (external Vo connection)

KCEG 242

Self powered three phase directional overcurrent and directional earth fault relay

Features per model	KCGG 122	KCGG 142	KCEG 112	KCEG 142	KCEG 152	KCEG 242
Selective directionalisation phase elements				●		●
Selective directionalisation earth elements			●	●	●	●
Rectifier protection curve	●	●	●	●	●	●
Thermal protection	●	●		●	●	●
Broken conductor detection	●	●	●	●	●	●
Dedicated breaker fail protection	●	●	●	●	●	●
Undervoltage				●		●
Under frequency		●		●	●	●
IEC/IEEE/ANSI curves	●	●	●	●	●	●
Phased output contacts	●	●		●	●	●
Cold load pick up	●	●	●	●	●	●
CB maintenance	●	●	●	●	●	●
Remote CB control	●	●	●	●	●	●
Disturbance recorder	●	●	●	●	●	●
Event recorder - last 50 records	●	●	●	●	●	●
Fault recorder - last 5 full records	●	●	●	●	●	●
Load shedding by level	●	●	●	●	●	●
Single phase watts and vars				●		●
Thermal ammeter	●	●		●	●	●
Peak thermal demand	●	●		●	●	●

Table 1: Relay models available

Application

The KCGG and KCEG overcurrent relays can be used in all applications where overcurrent protection is required, eg. radial and ring circuits, and single and parallel feeders. Furthermore, the integral starting elements can be used to provide non-cascade operation and busbar protection, with additional directional zone feeder protection available in the KCEG.

Thermal and restricted earth fault protection is also provided for lines and transformers. When used with the rectifier IDMT curve, this can provide full protection of silicon rectifiers.

The low settings of KCGG/KCEG relays are suitable for the protection of high impedance earthed systems. [For arc suppression earthed systems (Petersen Coil) see publication R6537.]

Undervoltage and underfrequency protection will operate for changes in system conditions or can be used to provide other protection and control functions.

Functions

Phase fault protection

Figure 2 shows the characteristics of the three phase overcurrent elements ($I>$, $I>>$ and $I>>>$), their respective time delays ($t>$, $t>>$ and $t>>>$) and the undercurrent element ($I<$).

The first phase element ($I>/t>$) in the relay has a choice of nine inverse and one definite time characteristic as shown in Figure 12.

This element has a reset timer to assist faster clearance of intermittent recurrent faults. There are two other elements [$(I>>/t>>)$ and $(I>>>/t>>>)$] for each phase function, which can be selectively disabled if not required.

Thermal overload protection

The thermal overload element is a true I^2 characteristic, with adjustable alarm and trip thresholds. The thermal state is stored in non-volatile memory.

Earth fault protection

The earth fault elements are designated ($Io>/to>$), ($Io>>/to>>$) and ($Io>>>/to>>>$), and their respective time delays are ($to>$, $to>>$, $to>>>$).

Directional elements (KCEG)

Directional fault elements are polarised by the quadrature phase-phase voltage. The phase directional elements are provided with synchronous polarization which is maintained after the voltage collapses so that decisive operation is ensured.

For KCEG 142/242 relays, the polarizing voltage ($-3Vo$) is internally derived from the three phase-neutral voltages applied to the relay. In the case of the KCEG 112/152, the

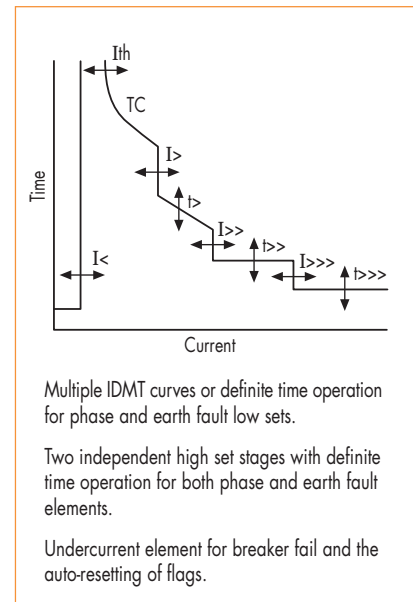

Figure 2: Overcurrent characteristic

polarizing voltage must be externally derived from an open delta winding on the line voltage transformers or via a voltage transformer in the earth path. The earth fault elements are provided with the same range of time and current settings.

Undercurrent elements and three phase loss of load

Two undercurrent elements are provided, one for phase faults ($I<$) and one for earth fault ($Io<$). The phase fault undercurrent element can be used for loss of load detection.

Circuit breaker failure and back-trip

This protection feature allows the relay to trip the upstream circuit breaker when a local breaker failure condition is detected and can be energised both from operation of the relay or an external trip. Figure 3 shows a typical back-trip method for a fault on Feeder 1 that should be cleared by Relay 2 and circuit breaker B (CB-B). If CB-B fails to clear the fault, it will be cleared by the back-trip contact of Relay 2 tripping CB-A.

Undervoltage protection (KCEG)

A separate characteristic can be set to provide an output for undervoltages which are phase-phase, phase-neutral, three phase or single phase.

An independently set timer, $tV <$ is used with this function which can allow a voltage controlled overcurrent feature to be created by switching between different current settings in the two groups. The undervoltage element can be blocked when the circuit breaker is open.

Underfrequency

A delayed underfrequency element is available which can be used to initiate direct load shed tripping.

Busbar protection

Protection of busbars can also be achieved by using the start and blocking contacts of the K relays. If in Figure 3, relay 1 has a standard IDMT characteristic for $I >$, but a fast acting $I >>$ element (time delay of typically 50ms) which is blocked by the downstream relays for feeder

faults, an economical form of busbar protection can be applied to a system. This can be used where dedicated busbar protection can not be justified.

Rectifier protection

A special inverse time curve provides protection for silicon rectifiers. Where used with the thermal overload, instantaneous short circuit and restricted earth fault protection, both the transformer and rectifier can be fully protected.

Broken conductor detection

The relay can provide a broken conductor alarm when it detects load current in only two out of three conductors.

Circuit breaker maintenance data

An alarm is provided to indicate the need for circuit breaker maintenance based upon the number of circuit breaker operations or upon the summated contact breaking duty. The circuit breaker trip time is stored in the fault records.

Configuration

Logic

The configuration of the relay, to meet the required applications, is accomplished in software. Setting logic function links, together with the assignment of inputs and outputs, define the way that the relay will operate. This allows:

- Selection of features
- Implementation of user defined logic using auxiliary timers
- Control of the integral disturbance and event recorder

These may be defined by the user via the relay front panel function keys, or remotely by a PC via the communications system.

Alternative setting group

Two setting groups allow the user to assign settings for different operating conditions. Several methods of selecting the alternative setting group are provided.

Ancillary Functions

Measurements

The measurement values provided by the relay can be accessed by an integral back-lit liquid crystal display or via the serial port eliminating the need for additional instrumentation to be mounted on the panel. The measurements can be displayed in either primary or secondary values as selected by the user.

The following quantities are provided as standard:

- phase current
- neutral current
- frequency
- thermal ammeter
- peak demand ammeter

Additional values are provided by the KCEG, as follows:

- phase voltage
- line voltage
- zero sequence voltage
- watts (single phase and three phase)
- VArS (single phase and three phase)
- volt amps
- power factor

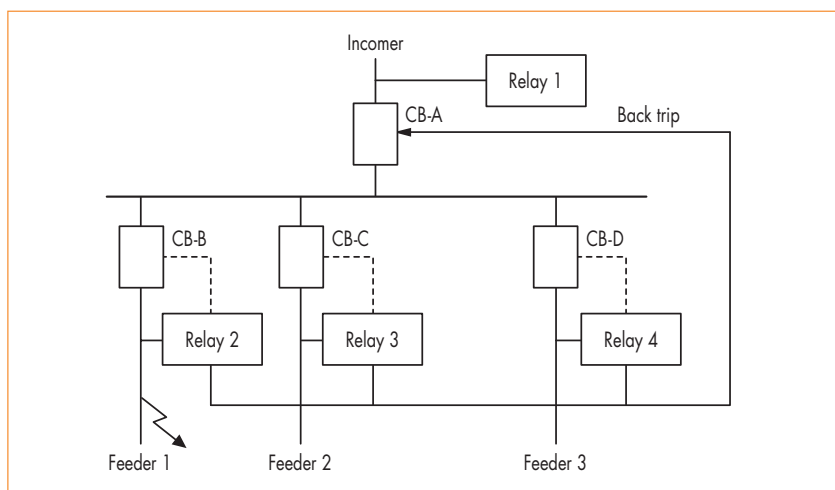

Figure 3: Back trip fault clearance

Fault records

The last five faults are recorded by the relay. They include:

- fault flags
- currents
- voltages (where measured)
- circuit breaker operation time

Event records

Fifty events are stored in a buffer.

Software is available to enable the events to be downloaded to a PC.

An event record is logged following a change of state of a control input or output relay, local setting change, or operation of a control function.

Records are time tagged to a resolution of 1ms. Fault records and alarms are also stored as events.

Disturbance records

The internal disturbance recorder has up to 7 analogue, 16 digital and 1 time channel (depending on the model selected). The recorder can be triggered from any relay output and/or digital input, and can store one complete record. Data is sampled 8 times per cycle and each channel can store up to 512 samples. Software is available to allow records to be accessed and displayed by a PC.

Test Features

A number of features are provided to enable the relay to be thoroughly tested during commissioning, routine maintenance and fault finding operations:

- Power-on diagnostics
- Continuous self monitoring
- The verification of input quantities by the measurement functions
- The on/off states of the digital inputs and relay outputs can be displayed

Hardware Description

KCGG and KCEG relays are housed in Midos modular cases, suitable for either rack or panel mounting as shown in Figures 13, 14 and 15.

The relays can have up to 4 CT and up to 3 VT analogue inputs. They provide 3 or 8 optically isolated inputs and 4 or 8 programmable outputs depending on the model selected, together with a dedicated watchdog relay.

The front panel contains a 2 x 16 character alphanumeric back-lit liquid crystal display (LCD). The back-light is activated when the keypad is touched and will automatically switch off, conserving power, after 15 minutes of keypad inactivity. Four push-buttons provide local access to the relay's menu. There are also 3 light emitting diodes (LED) for visual indication of the relay's status, ie. relay healthy, trip, alarm.

Standard Midos terminal blocks are located at the rear of the relay providing connections for all input and output circuits. Each terminal will accept up to two connections using either; an 'L' shaped ring connector fastened with a 4mm diameter (M4) screw or; a snap-on connector compliant with BS5057 or equivalent.

User Interface

Front panel user interface

The features of the relay can be accessed through a menu driven system. The menu is arranged in the form of a table, into each column of which, related items (menu cells) are grouped.

The front panel LCD displays one menu cell at a time. The complete menu system can be traversed with the relay's front cover in place by using the 'F' key. Easier access can be made with the cover off by using the '+' and '-' keys, which are also used to change the relay settings.

Remote access user interface

The menu table can also be accessed via the remote communications facility. This allows all of the menu cells in a column to be displayed simultaneously on the screen of a PC. Changes to a menu cell can be made from the PC keyboard.

Serial communication

The relays are interconnected via a shielded, twisted wire pair known as K-Bus. Up to 32 relays may be connected in parallel across the bus.

The K-Bus is connected through a protocol converter known as KITZ, either directly or via a modem, to the RS232 port of the PC. The KITZ provides signals over the bus which are RS485 based and are transmitted at 64kbits/s. The K-Bus connection is shown in Figure 5.

This system allows up to 32 relays to be accessed through one RS232 communications port. A pictorial representation of this is shown in Figure 4.

Software is available with each KITZ to provide access to the relay to read and change settings. Additional software entitled 'Protection Access Software & Toolkit' is available. This provides access to the event recorder and other additional functions.

Each relay is directly addressable over the bus to allow communication with any selected relay. Global commands may also be given to all relays on the network.

It should be noted that protection tripping and blocking signals are not routed via the K-Bus. Separate conventional cabling is used for this purpose; where appropriate the isolated 48V dc supply available on each relay is used to energise the optically-isolated inputs.

Communications protocol

The communications protocol used with K Range relays is designated Courier. The Courier language has been developed specifically for the purpose of developing generic PC programs that will, without modification, communicate with any device using the Courier language. In the Courier system, all information resides within the relay. Each time communication is established with the relay, the requested information is loaded to the PC. The protocol includes extensive error checking routines to ensure the system remains reliable and secure.

Password protection

Password protection is provided on settings which alter the configuration of the relay, any accidental change to which could seriously affect the ability of the relay to perform its intended function, ie. enable/disable settings, protection function characteristic selection, scheme logic settings and system VT and CT ratios.

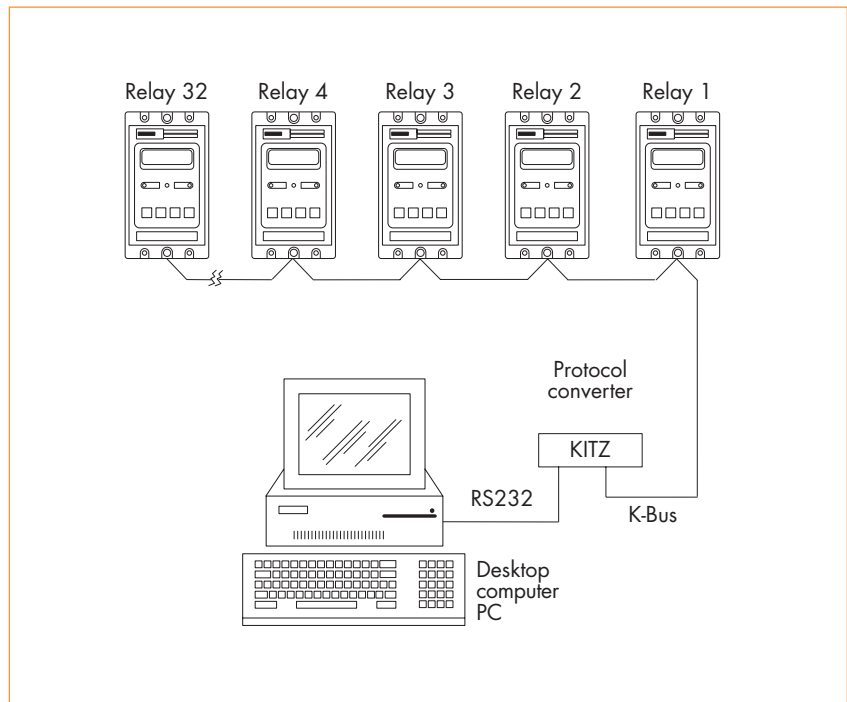

Figure 4: Basic communication system

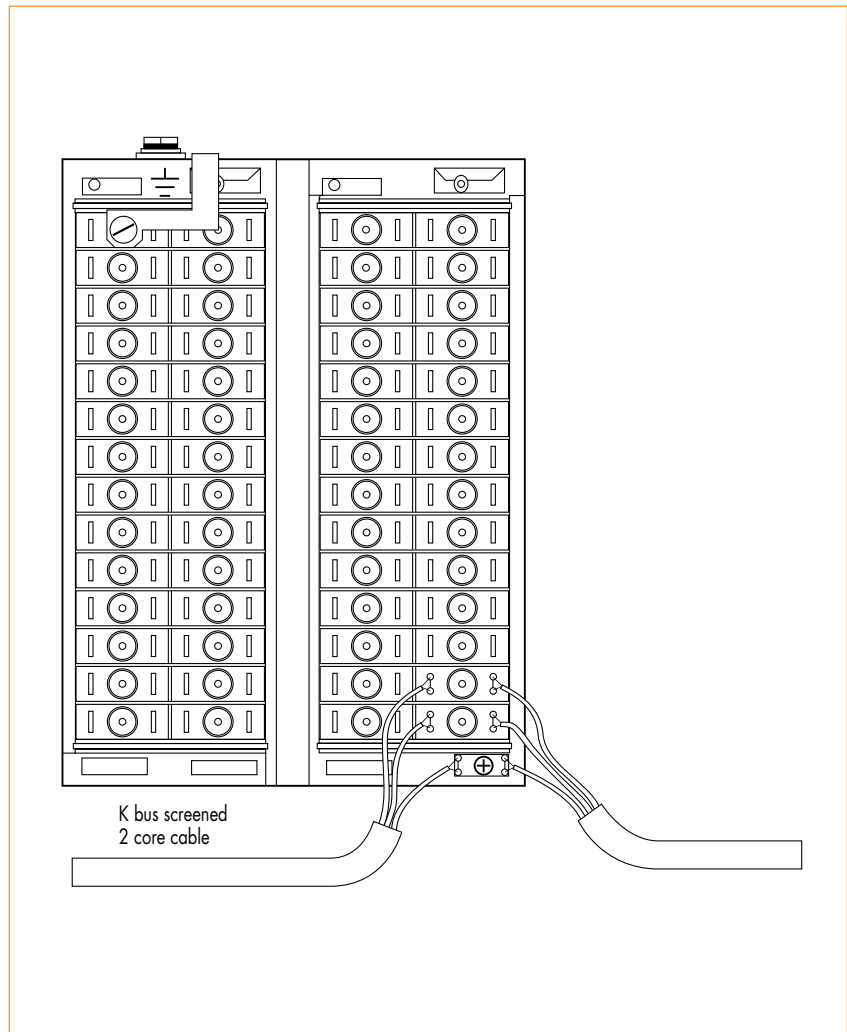

Figure 5: Typical communications terminal arrangement

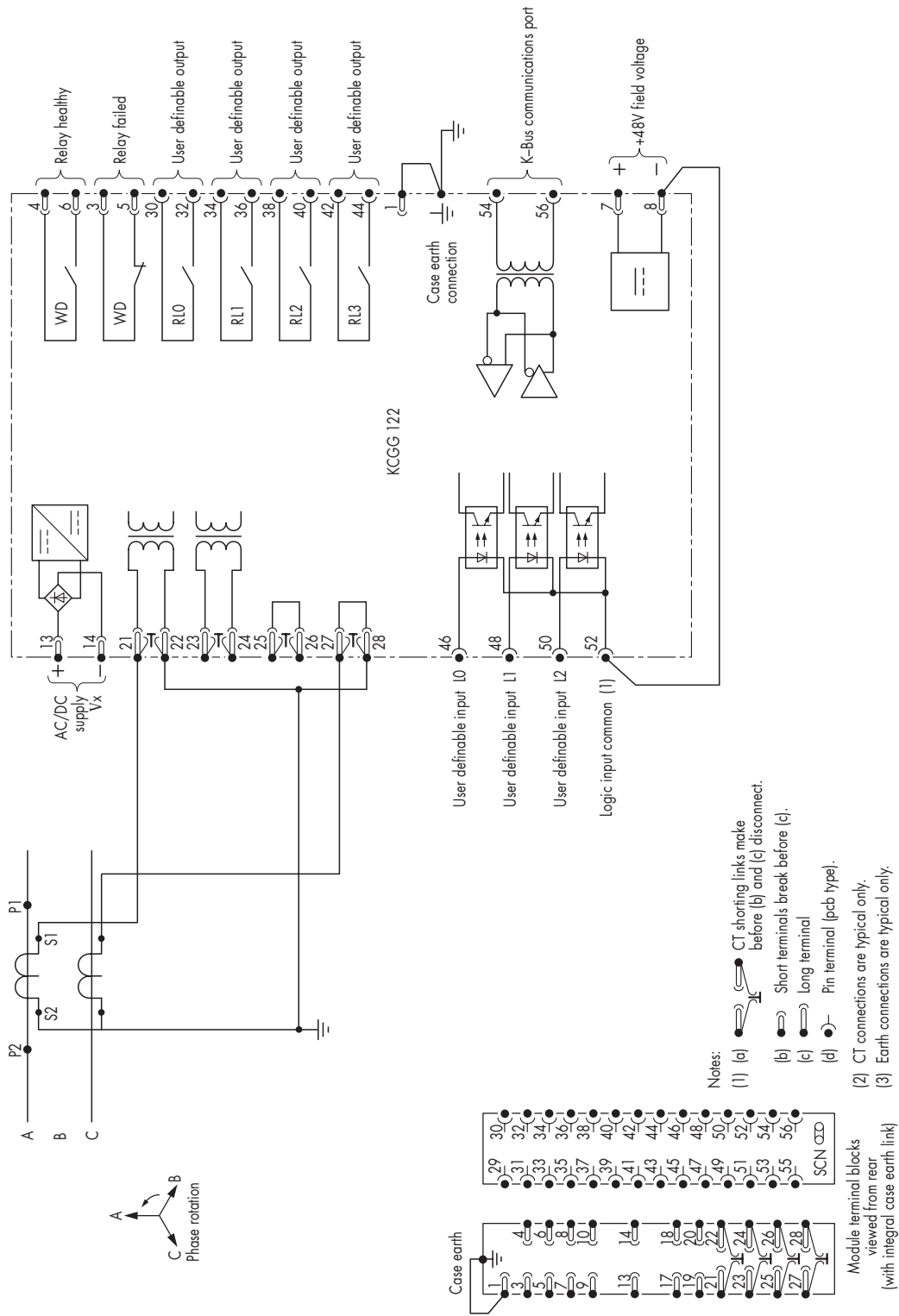

Figure 6: Typical application diagram KCGG 122

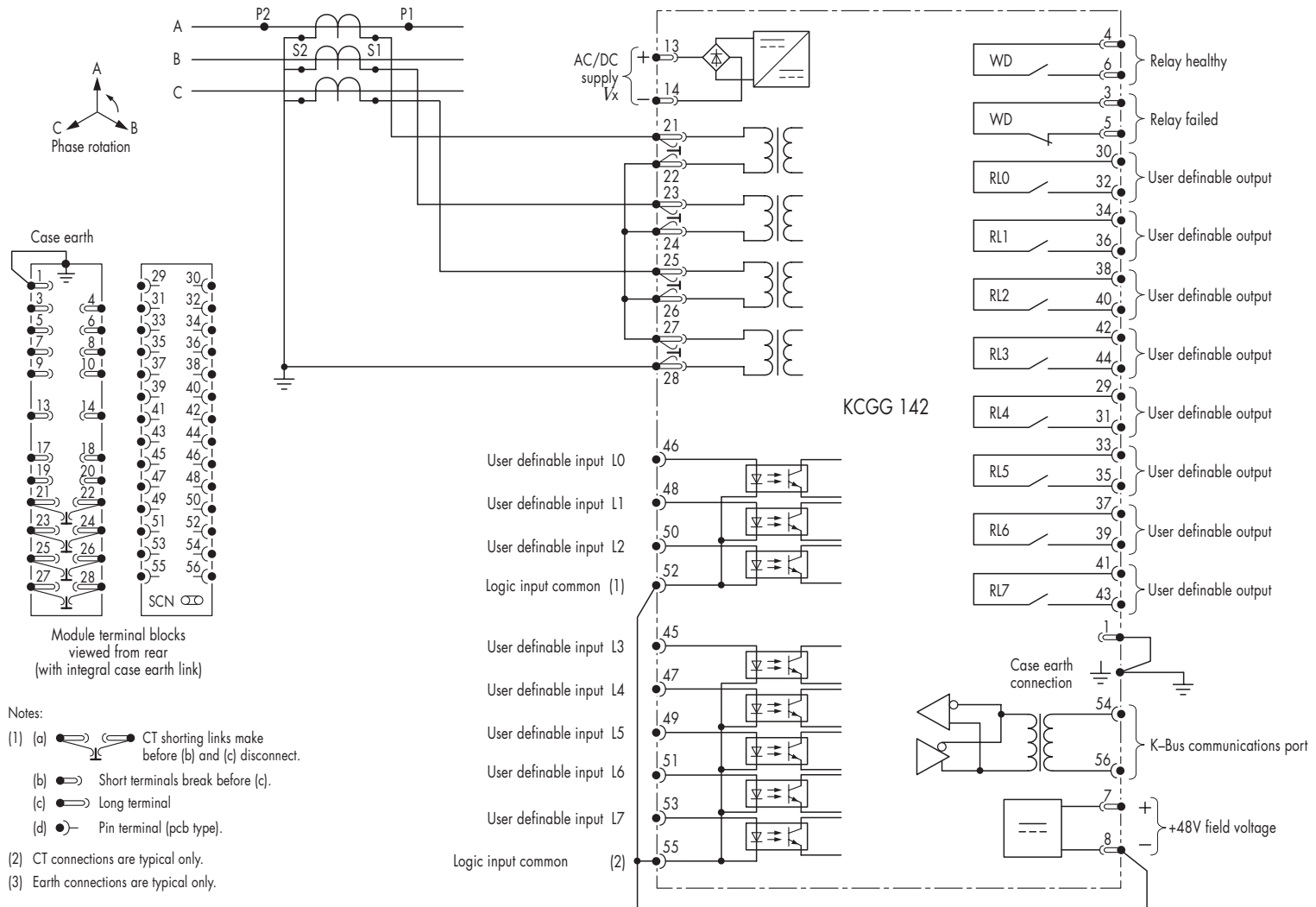

Figure 7: Typical application diagram KCGG 142

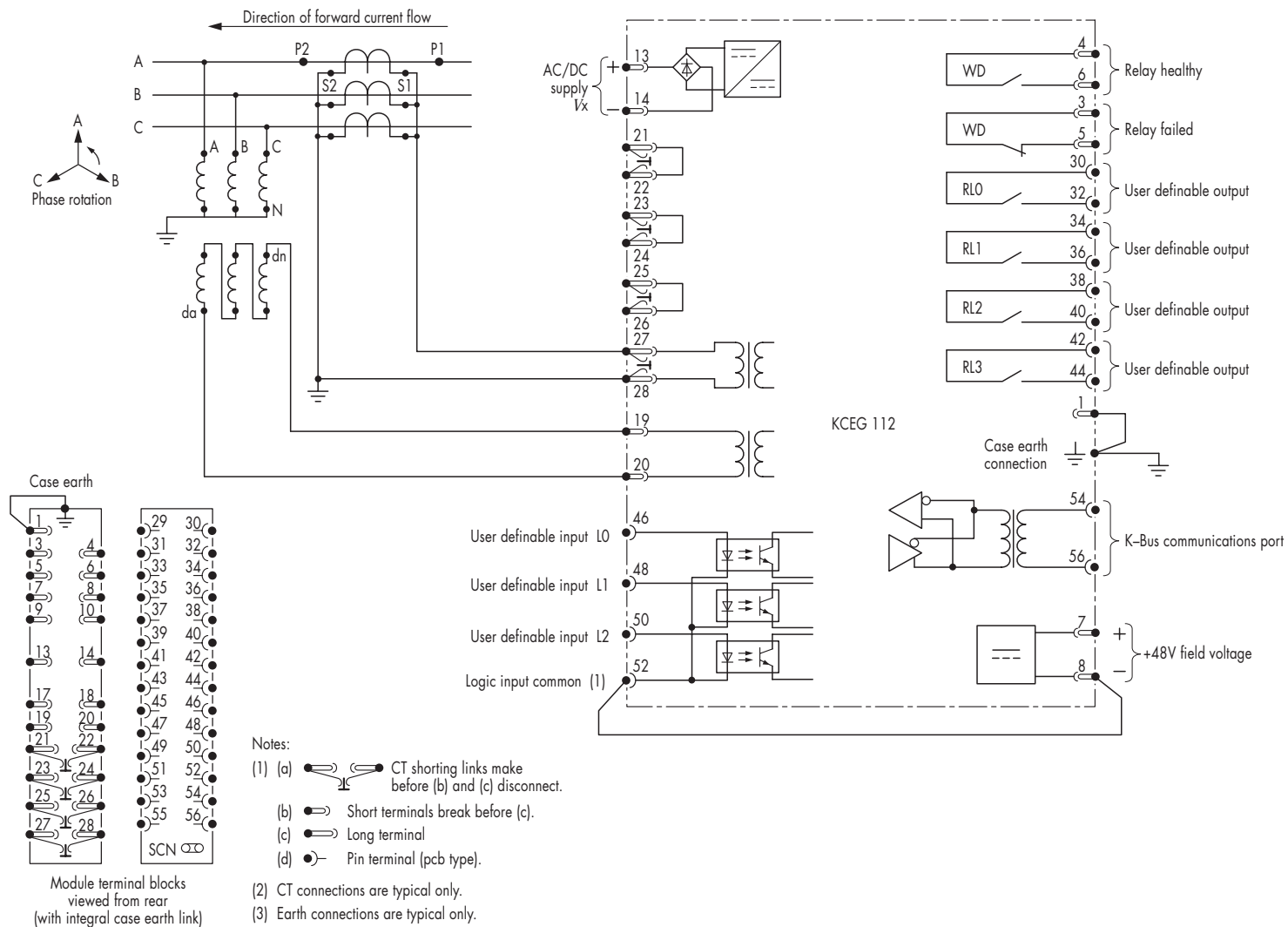

Figure 8: Typical application diagram KCEG 112

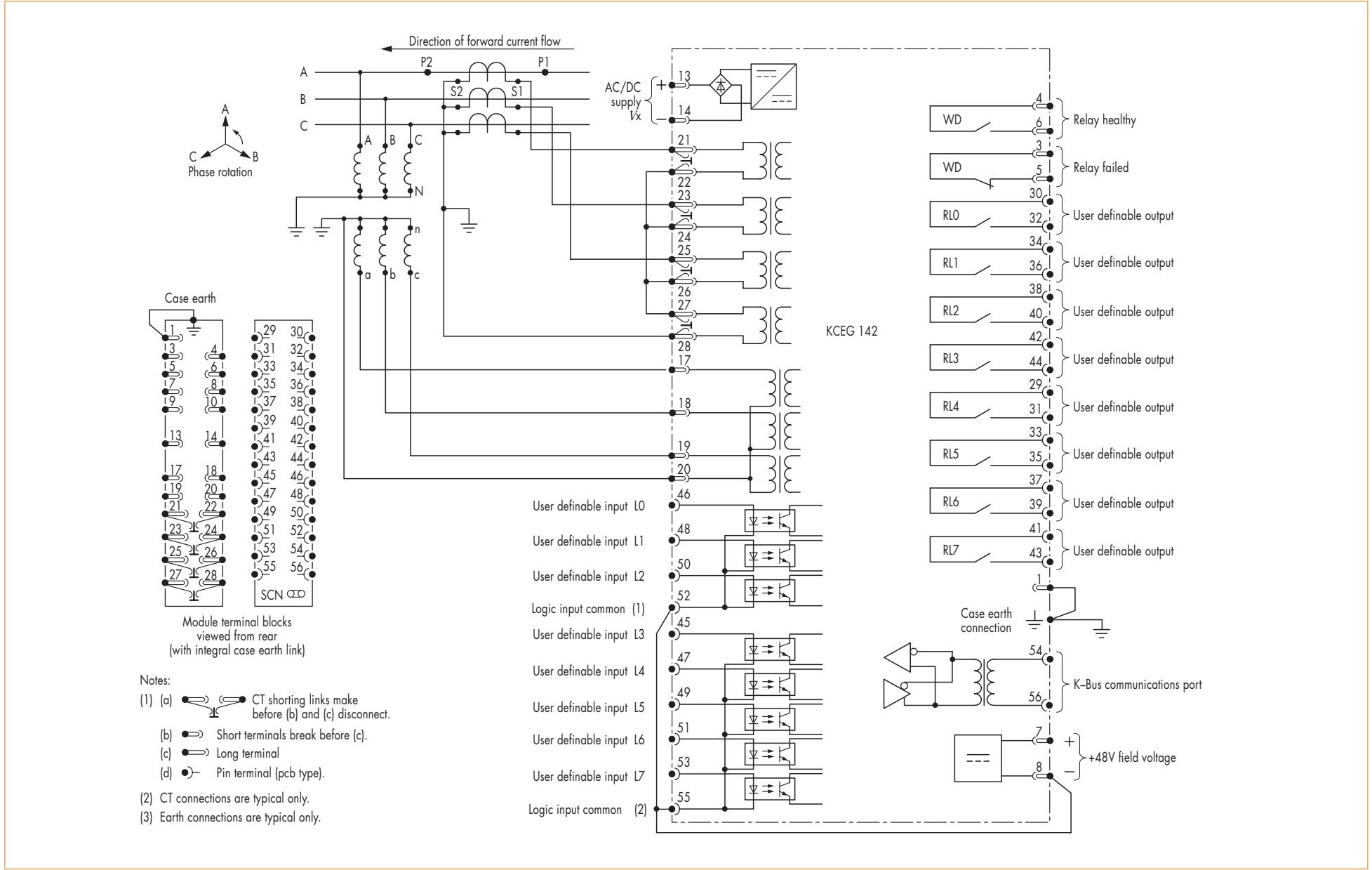

Figure 9: Typical application diagram KCEG 142

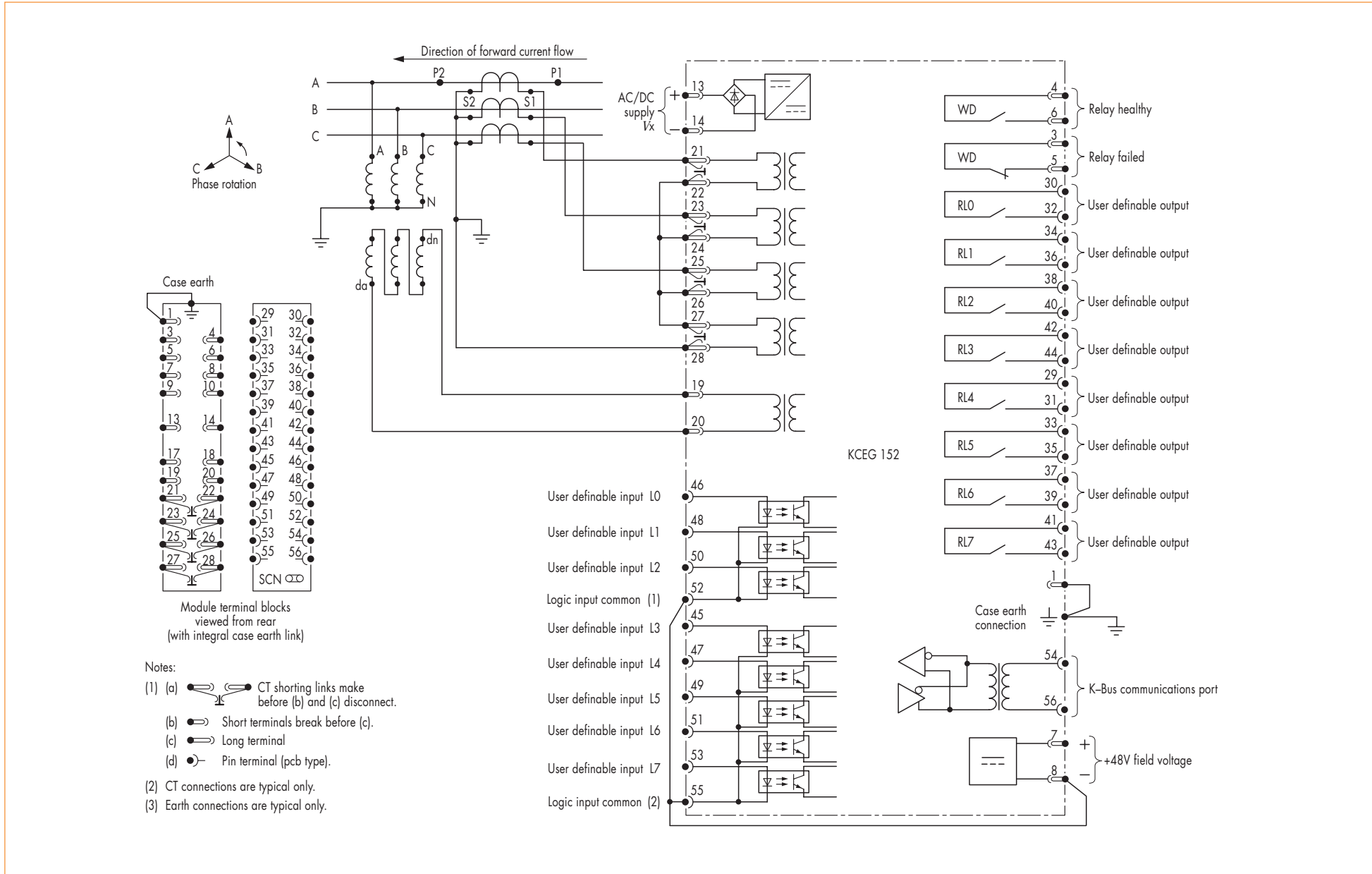

Figure 10: Typical application diagram KCEG 152

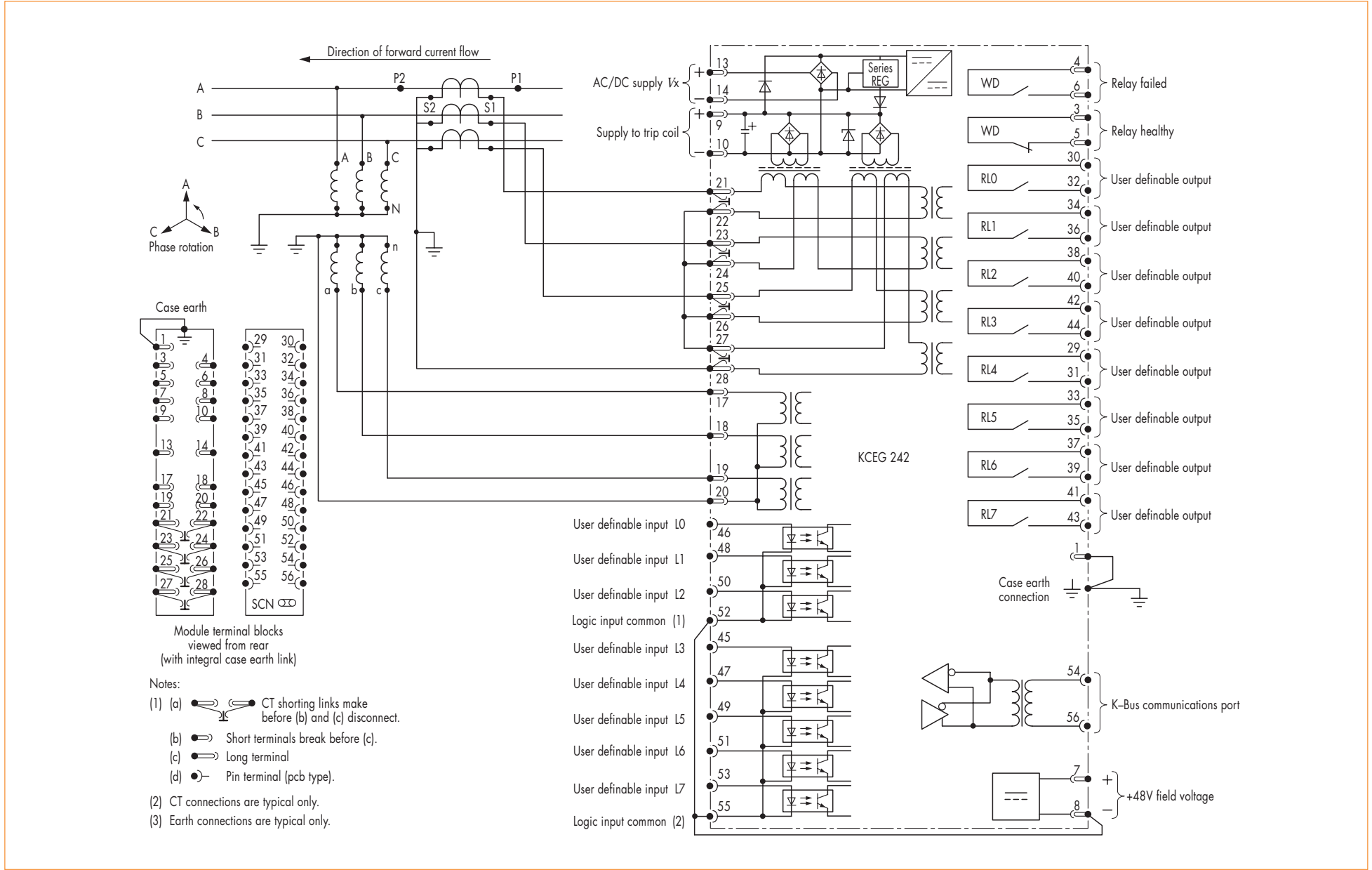

Figure 11: Typical application diagram KCEG 242

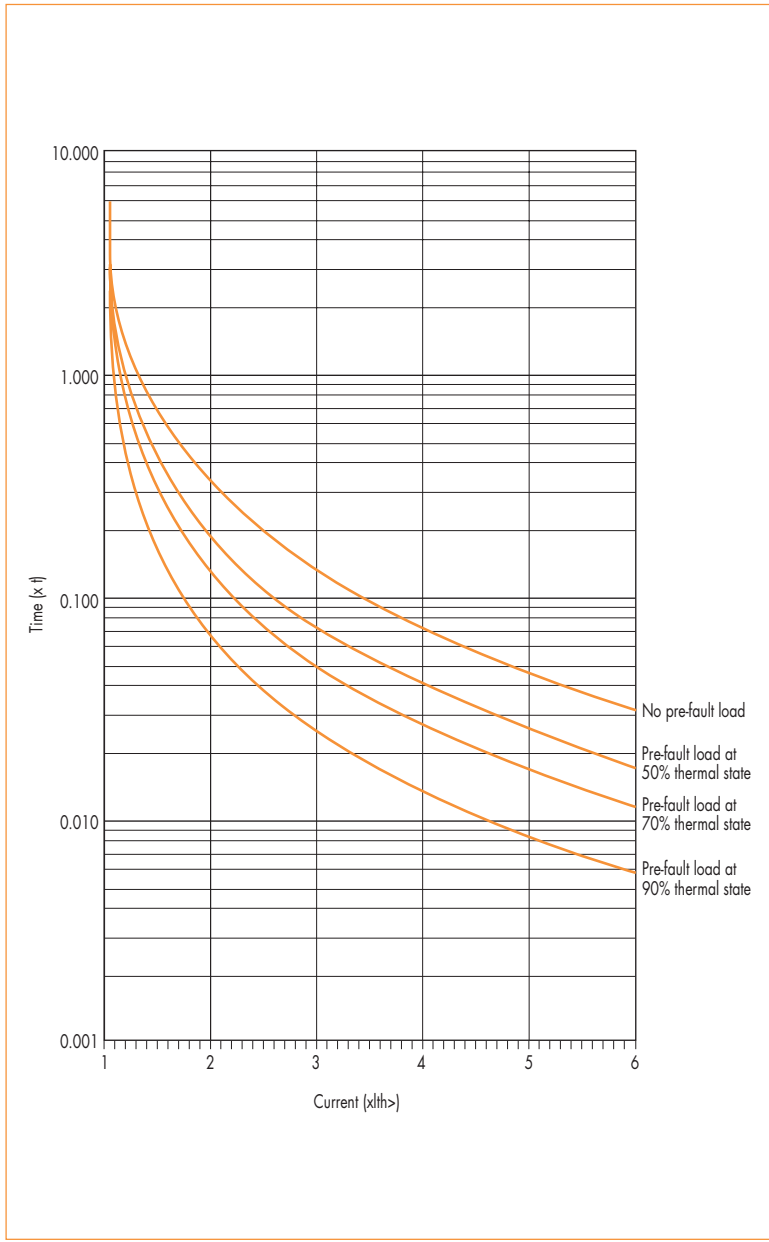
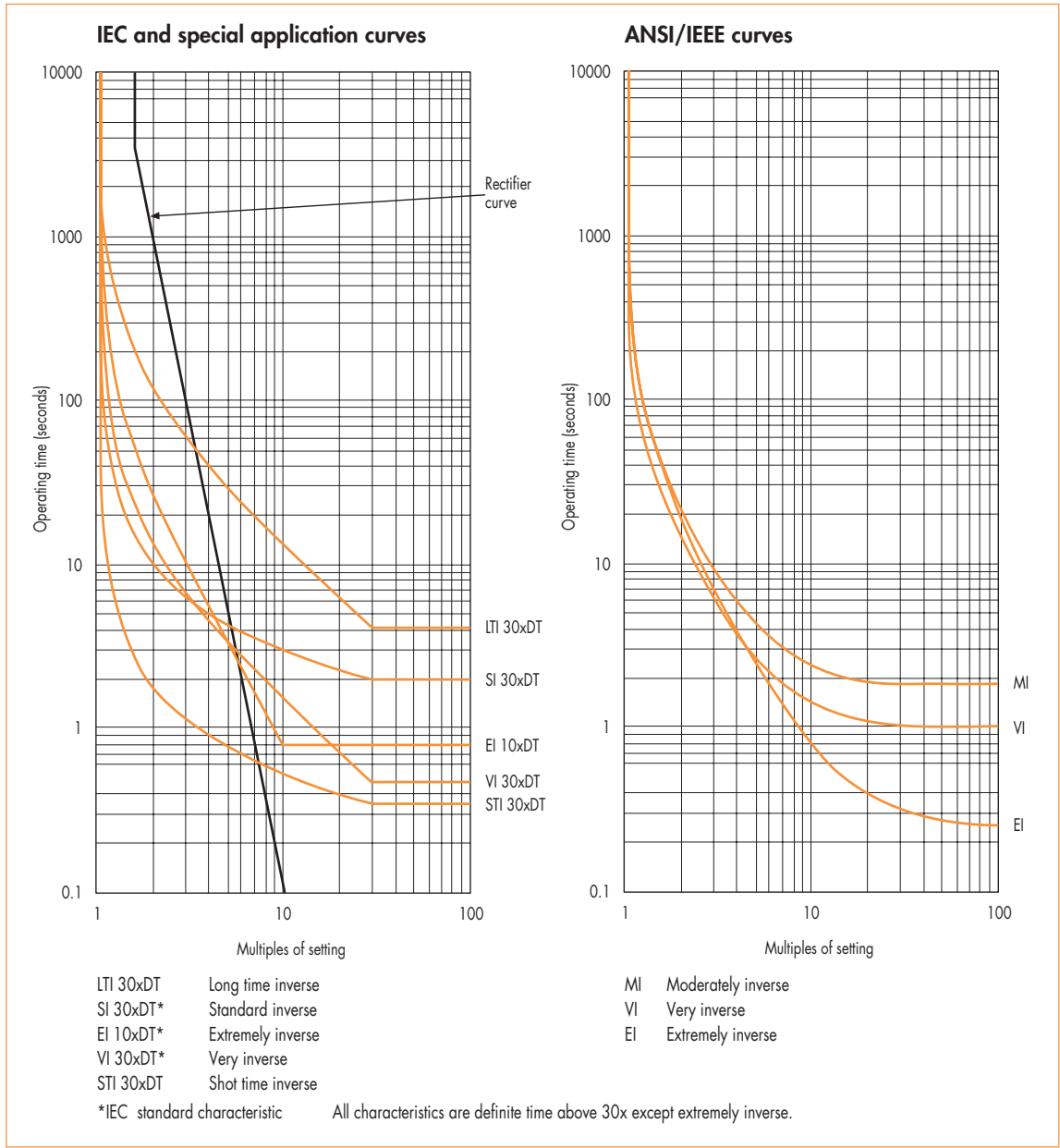

Figure 12: IDMT curves.

Figure 13: Thermal curves

Technical Data

Ratings

Inputs:

AC current (I _n)	1 A or 5 A
AC voltage (V _n)	110V or 440V nominal phase-phase
Frequency	50/60Hz

Auxiliary voltage (V_x)

KCGG 122,142 and KCEG 112,142,152		
Nominal (V)	Operative range (V)	
	dc	ac
24/125 or 48/250	19/150 33/300	50/153 87/265
KCEG242 only		
100/250	60/300	60/265

Outputs:

Field voltage supply (for optically-isolated digital inputs)	48V dc (current limit: 60mA)
Capacitor discharge trip	50V dc, 680μF

Burdens

AC current	0.02VA at I _n = 1 A 0.03VA at I _n = 5 A
AC voltage	0.02VA at 110V phase-phase
DC auxiliary voltage	4W to 12W*
AC auxiliary voltage	6VA to 23VA*
Optically-isolated inputs	0.25W per input

*Note: Depending on the number of inputs and outputs energised.

Thermal withstand

AC current inputs	3.2I _n continuous 30I _n for 3s
AC voltage inputs	2 x V _n continuously 2.6V _n for 10s where V _n = 110V phase-phase

Accuracy

Operating times

t _{>/t_o>}	Typically ±5% plus 20 – 40ms
t _{>>/t_o>>/t_{>>>/t_o>>>}}	Typically ±0.5% plus 10 – 45ms

Reset time

t _{>/t_o>}	Typically ±1% ±50ms
-------------------------------------	---------------------

Measurements

Voltage	Typically ±2% V _n
Current	Typically ±2% I _n
Power	Typically ±4% P _n
Frequency	Typically ±0.02Hz

Transformer turns ratios

Current transformers	1:1 to 9999:1
Voltage transformers	1:1 to 9999:1

Current transformer requirements

The following CT requirements are based on a maximum prospective fault current of $50I_n$ and the relay having a maximum high setting of $25I_n$. The CT requirements are designed to provide operation of the phase and earth fault elements. When the criteria for a specific application are in excess of those detailed above or the actual resistance exceeds the limiting value quoted, the CT requirements may need to be increased. CT requirements for a variety of further applications are provided in publication R6096. Where the relays are being used for restricted earth fault protection the CTs must be of the correct size to assure stability as described in publication R4120.

KCGG 122,142 and KCEG 112,142,152				
Relay and CT secondary rating (A)	Nominal output (VA)	Accuracy class	Accuracy limit factor x rated current	Limiting lead resistance one way Ω
1	2.5	10P	20	0.6
5	7.5	10P	20	0.06
KCEG242				
1	7.5	10P	15	0.7
5	10	10P	20	0.06

Overcurrent settings

Phase fault

	Threshold (I_s)	
	KCGG 122,142 KCEG 112,142,152	KCEG 242
$I>$	0.08 – $3.2I_n$	0.4 – $2.4I_n$
$I>>$	0.08 – $32I_n$	0.4 – $32I_n$
$I>>>$	0.08 – $32I_n$	0.4 – $32I_n$
$I<$	0.02 – $3.2I_n$	0.02 – $3.2I_n$

Earth fault

	All models	
	Standard	Special (provided on request)
$I_{o>}$	0.005 – $0.8I_n$	0.02 – 3.2^*
$I_{o>>}$	0.005 – $8.0I_n$	0.02 – $32I_n^*$
$I_{o>>>}$	0.005 – $8.0I_n$	0.02 – $32I_n^*$
$I_{o<}$	0.005 – $0.8I_n$	0.02 – $3.2I_n$

*Notes: 1. For operation for earth faults below $0.2I_n$ with the KCEG 242, there must be sufficient load current to power the relay or alternatively, an auxiliary voltage supply.

2. The special settings may be required where limitations on the CT ratio result in a need for an unusually high earth fault setting. Otherwise the standard setting range should be chosen.

Thermal Alarm	0 – 110% of thermal state
$I_{th>}$	0.08 – $3.2I_n$
t_c	1 to 120 minutes

Directional settings (KCEG)

Characteristic angle	-180° to +180° in 1° steps
Zone of operation	Characteristic angle $\pm 90^\circ$
Voltage polarising threshold (overcurrent directional elements)	110Vn: 0.6V fixed 440Vn: 2.4V fixed
Voltage polarising threshold Vop> (earth fault directional elements)	110Vn: 0.6V to 80V in 0.2V steps 440Vn: 2.4V to 320V in 0.8V steps
Undervoltage trip threshold V<	110Vn: 1.0V to 220V in 1.0V steps 440Vn: 4.0V to 880V in 4.0V steps
Undervoltage V<	Vn = 110V: 0 to 220V Vn = 440V: 0 to 880V
Underfrequency F< Reset	46 to 64Hz in 0.01Hz steps F< +0.05Hz

Time settings (in graded steps)

to>/t> (definite time)	0 to 100s
tRESET	0 to 60s
to>>/t>>	0 to 100s
to>>>/t>>>	0 to 100s
tV<	0 to 10s
tAUX 1	0 to 2 x 10 ⁶ s (24 days)
tAUX 2	0 to 2 x 10 ⁶ s (24 days)
tAUX 3	0 to 2 x 10 ⁶ s (24 days)
tBF	0 to 10s
tTRIP/tCLOSE	0.5s to 5s
IDMT curves	See Figure 12.

Digital inputs

Optically-isolated inputs	3 (KCGG 122/KCEG 112) 8 (All other models)
Maximum operating voltage	>35V dc
Maximum input resistance	50V dc
AC immunity	50V

Contacts

Output relays	4 (KCGG 122/KCEG 112) 8 (All other models)
Contact rating	Make: 30A and carry for 0.2s Carry: 5A continuous Break: dc 50W resistive 25W inductive (L/R = 0.04s) ac 1250VA Subject to maxima of 5A and 300V.
Watchdog relays	1 make and 1 break Make: 10A and carry for 0.2s Carry: 5A continuous Break: dc 30W resistive 15W inductive (L/R = 0.04s) ac 1250VA Subject to maxima of 5A and 300V.

Durability	
Loaded contact	10,000 operations minimum
Unloaded contact	100,000 operation minimum
Communications port (K-Bus)	
Transmission mode	Synchronous
Signal levels	RS485
Message format	HDLC
Data rate	64 kbits/s
Connection	Multidrop (32 units)
Cable type	Screened twisted pair
Cable length	1000m
Connector	Screw terminals
Isolation	2kV rms for 1 minute

High voltage withstand

Dielectric withstand IEC 255-5: 1977	2kV rms for 1 minute between all case terminals (except terminals 1) connected together and the case earth/terminals 1. 2kV rms for 1 minute between all terminals of independent circuits with terminals on each independent circuit connected together. 1.5kV rms for 1 minute across open contacts of output relays. 1kV rms for 1 minute across the open contacts of the watchdog relays.
---	--

High voltage impulse IEC 255-5: 1977	Three positive and three negative impulses of 5kV peak, 1.2/50 μ s, 0.5J between all terminals and all terminals (except terminals 1) and case earth/terminal 1.
---	--

Electrical Environment

DC supply interruption IEC 255-11: 1979	10ms interruption in the auxiliary supply.
--	--

AC ripple on dc supply IEC 255-11: 1979	12% ac ripple on the dc supply.
--	---------------------------------

High frequency disturbance IEC 255-22-1: 1988 Class III	2.5kV peak between independent circuits and case. 1.0kV peak across terminals of the same circuit.
--	---

Fast transient disturbance IEC 255-22-4: 1992 Class IV	4kV, 5kHz applied directly to all inputs. 4kV, 2.5kHz applied directly to auxiliary voltage, watchdog and trip capacitor. 4kV, 2.5kHz via capacitor clamp to all inputs.
---	--

	Electrostatic discharge IEC 255-22-2: 1996 Class 3	8kV discharge in air with cover in place. 4kV point contact discharge with cover removed.
	EMC Compliance 89/336/EEC	Compliance to the European Commission Directive on EMC is claimed via the Technical Construction File route.
	EN 50081-2: 1994 EN 50082-2: 1995	Generic Standards were used to establish conformity.
	Product safety 73/23/EEC	Compliance with European Commission Low Voltage Directive.
	EN 61010-1: 1993/A2: 1995 EN 60950: 1992/A3: 1995	Compliance is demonstrated by reference to generic safety standards.
	Atmospheric environment	
	Temperature IEC 68-2-1: 1990 (cold) IEC 68-2-2: 1974 (dry heat)	Storage and transit –25°C to +70°C Operating –25°C to +55°C
	Humidity IEC 68-2-3: 1969	56 days at 93% RH and +40°C
	Enclosure Protection IEC 529: 1989	IP50 (dust protected)
	Mechanical environment	
	Vibration IEC255-21-1: 1988	Response Class 1 Endurance Class 1
	Shock and bump IEC255-21-2: 1988	Shock response Class 1 Shock withstand Class 1 Bump Class 1
	Seismic IEC255-21-3: 1993	Class 1
	IEEE/ANSI tests C37.90.2 - 1989	Standard for relay systems associated with electrical power apparatus.
	C39.90.1 - 1989	Surge withstand capability (SWC)
	C37.90.2 - 1987	Radio electromagnetic interference (with amended field strength of 35V/m)

Cases

KCGG122	
KCGG142	Midos size 4
KCEG112	
KCEG142	
KCEG152	Midos size 6
KCEG242	
	Midos size 8

Case outlines are shown in Figures 14, 15 and 16.

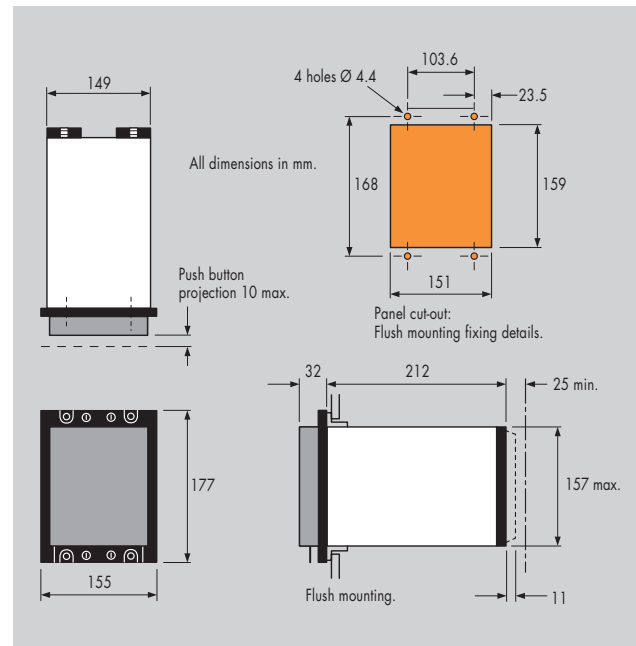

Figure 15: Case outlines size 6

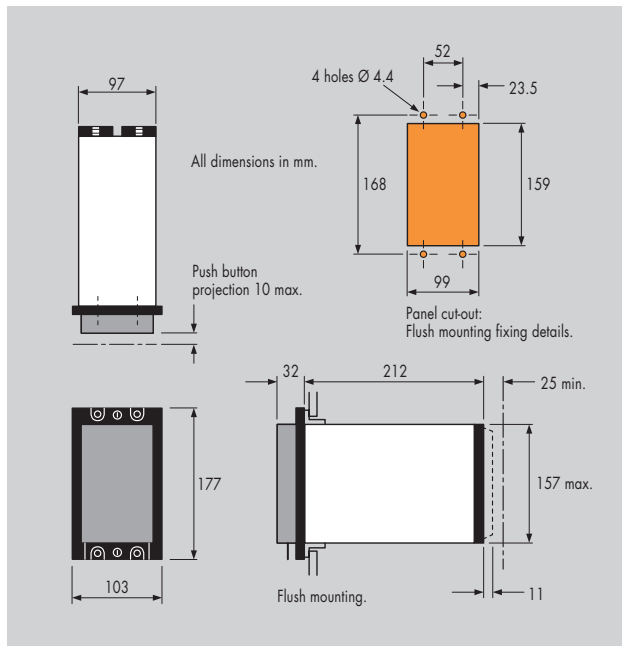

Figure 14: Case outlines size 4

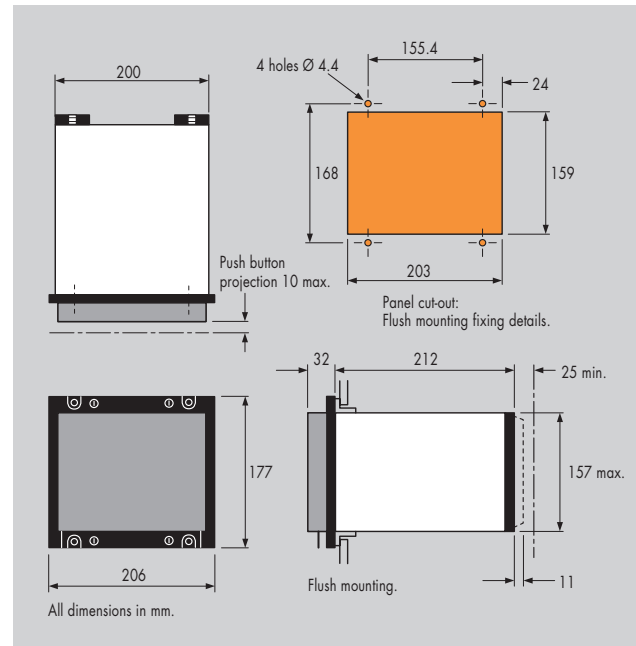

Figure 16: Case outlines size 8

Additional information

Service Manual	R8551
Courier Communications	R4113
CT Requirements for the Application of Midos Relays	R6096
K Range Relay Schemes	R6536
KCEU141/241	R6537
KITZ101/102/103	R6521
KITZ201	R6542
Restricted Earth Fault Protection using K Range Overcurrent Relays	R4120

Information required with order

Relay type:	K C G G	<input type="checkbox"/>	<input type="checkbox"/>	<input type="checkbox"/>	<input type="checkbox"/>	<input type="checkbox"/>	<input type="checkbox"/>	<input type="checkbox"/>	<input type="checkbox"/>	<input type="checkbox"/>	<input type="checkbox"/>	<input type="checkbox"/>
					0	1	D	0				
122		1	2	2								
142		1	4	2								
Configuration:												
Standard					0	1						
Case size:												
Size 4 MIDOS Flush Mounting							D					
Auxiliary voltage:												
24/125V								2				
48/250V								5				
Not used												
CT Rating:												
1A CT (0.005In to 0.8In for earth faults) standard												C
1A CT (0.02In to 3.2In for earth faults) special												D
5A CT (0.005In to 0.8In for earth faults) standard												E
5A CT (0.02In to 3.2In for earth faults) special												F
Language:												
English												E
French												F
German												G
Spanish												S

* Note: See 'Overcurrent settings', page 15.

It will be assumed that the standard version will be required unless otherwise stated in the order.

Relay type:	K	C	E	G		0	1					
112	1	1	2									
142	1	4	2									
152	1	5	2									
242	2	4	2									
Configuration:												
Standard						0	1					
Case size:												
Size 4 MIDOS Flush Mounting (KCEG112 only)												D
Size 6 MIDOS Flush Mounting (KCEG142/152 only)												F
Size 8 MIDOS Flush Mounting (KCEG242 only)												H
Auxiliary voltage:												
24/125V (except KCEG242)												2
48/250V (except KCEG242)												5
110/250V (KCEG242 only)												9
Operating Voltage:												
110 Vac; 50 - 60Hz												1
440 Vac; 50 - 60Hz												4
CT Rating:												
1A CT (0.005In to 0.8In for earth faults) standard												C
1A CT (0.02In to 3.2In for earth faults) special												D
5A CT (0.005In to 0.8In for earth faults) standard												E
5A CT (0.02In to 3.2In for earth faults) special												F
Language:												
English												E
French												F
German												G
Spanish												S

* Note: See 'Overcurrent settings', page 15.
It will be assumed that the standard version will be required unless otherwise stated in the order.

Glossary

Courier	A communications language developed to provide generic control, monitoring, data extraction and setting changes on remote devices (primarily on protective relays) within the substation environment.
K-Bus	The 64 kbit/s twisted pair cable used to connect Courier compatible devices and transfer Courier data.
KITZ	The interface unit which converts between K-Bus and IEC870 format data.
PC	Personal computer

