

◆Si NPN

◆RoHS COMPLIANT

1. APPLICATION

Fluorescent Lamp、Charger
and Switch-mode power supplies

2. FEATURES

- High voltage capability
- Features of good high temperature
- High switching speed

3. PACKAGE

TO-92T

4. Electrical Characteristics

4.1 Absolute Maximum Ratings

$T_{amb}=25^{\circ}\text{C}$ unless specified

PARAMETER		SYMBOL	VALUE	UNIT
Collector-Base Voltage		V_{CBO}	700	V
Collector-Emitter Voltage		V_{CEO}	400	V
Emitter- Base Voltage		V_{EBO}	9	V
Collector Current		I_C	1.0	A
Power Dissipation	$T_a=25^{\circ}\text{C}$	P_{tot}	0.8	W
	$T_c=25^{\circ}\text{C}$		11	
Junction Temperature		T_j	150	$^{\circ}\text{C}$
Storage Temperature		T_{stg}	-55~150	$^{\circ}\text{C}$

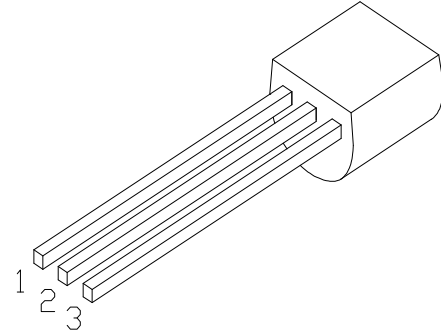

1 Base(B) 2 Collector(C) 3 Emitter(E)

4.2 Electrical Parameter

$T_{amb}=25^{\circ}\text{C}$ unless specified

PARAMETER	SYMBOL	TEST CONDITION	VALUE			UNIT
			MIN	TYP	MAX	
Collector-Base Voltage	BV_{CBO}	$I_C=1\text{mA}, I_E=0$	700			V
Collector-Emitter Voltage	BV_{CEO}	$I_C=1\text{mA}, I_B=0$	400			V
Emitter-Base Voltage	BV_{EBO}	$I_E=1\text{mA}, I_C=0$	9			V
Collector-Base Cutoff Current	I_{CBO}	$V_{CB}=700\text{V}, I_E=0$			10	μA
Collector-Emitter Cutoff Current	I_{CEO}	$V_{CE}=400\text{V}, I_B=0$			20	μA
Emitter-Base Cutoff Current	I_{EBO}	$V_{EB}=9\text{V}, I_C=0$			10	μA
DC Current Gain	h_{FE}^*	$V_{CE}=5\text{V}, I_C=1\text{mA}$	8			
		$V_{CE}=5\text{V}, I_C=100\text{mA}$	15		30	
Collector-Emitter Saturation Voltage	$V_{CE\text{ sat}}^*$	$I_C=500\text{mA}, I_B=250\text{mA}$			0.6	V
Base-Emitter Saturation Voltage	$V_{BE\text{ sat}}^*$	$I_C=500\text{mA}, I_B=250\text{mA}$			1.2	V
Rising Time	t_r	$I_C=100\text{mA} \quad (UI9600)$			0.7	μs
Falling Time	t_f				0.9	
Storage Time	t_s		2.0		3.5	
Typical Frequency	f_T	$V_{CE}=10\text{V}, I_C=0.1\text{A}, f=1\text{MHz}$	5			MHz

* : Pulse test $t_p \leq 300 \mu\text{s}, \delta \leq 2\%$

5. Characteristic Curve

Fig1 Static Characteristic

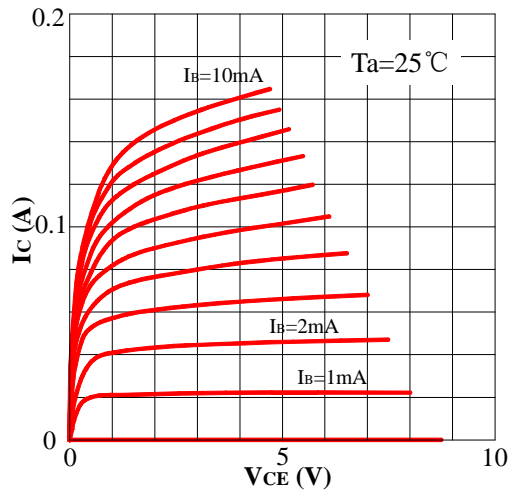

Fig2 h_{FE} - I_C

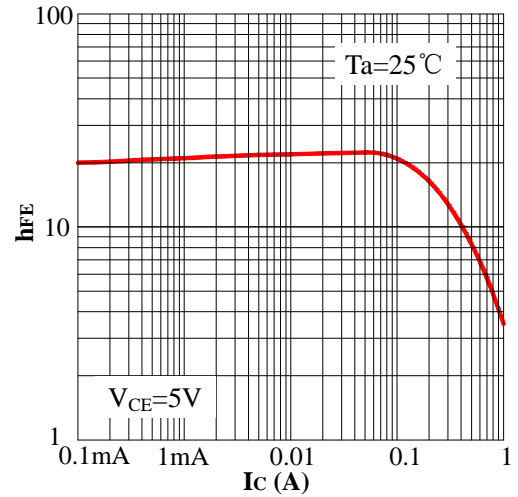

Fig3 V_{CEsat} - I_C

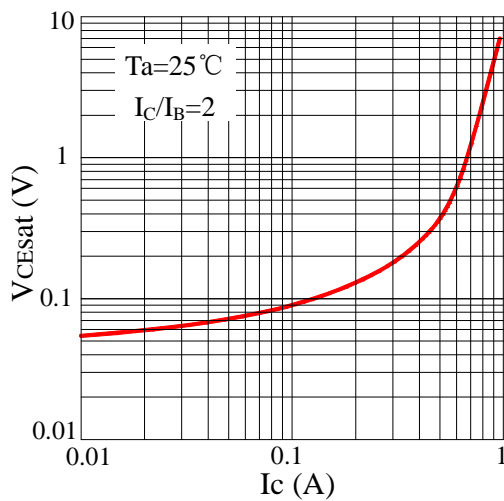
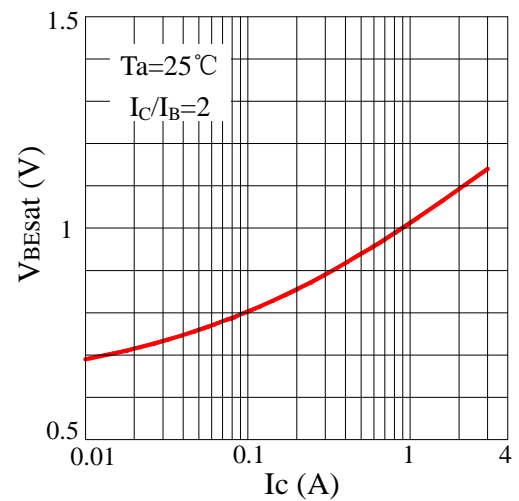

Fig4 V_{BEsat} - I_C



6. Package Dimentions(Unit: mm)

T0-92T

